



**Class 1 Green  
LED Rotating Beacon**  
#101300

www.ionnic.com



**5 Year LED warranty**

**DESCRIPTION**

12 - 36 Volt Class 1 rated aerodynamic low profile green beacon. Made from polycarbonate lens and epoxy filled base, delivering a rugged shock resistant beacon.

Features 5 different flash patterns, powered by 12 x 3W LED's with included dimming function and 2 simulated rotating options (120FPM). Environmentally sealed (IP67), dust and water resistant. Complies to Australia's heavy vehicle regulations.

Ideal to suit all heavy duty applications in a commercial or construction environments

**TECHNICAL SPECIFICATIONS**

<b>Voltage</b>	• 12 - 36 Volt	<b>Mounting</b>	• 3 bolt mount
<b>Current Draw</b>	• 2.8A @ 12 Volt	<b>Colour</b>	• Green
<b>IP Rating</b>	• IP67 rated	<b>Dimensions</b>	• 162mm (D) x 89mm (H)
<b>Lens Material</b>	• Polycarbonate lens	<b>Flash Patterns</b>	• 5 flash patterns
<b>Base Material</b>	• Aluminium, epoxy sealed	<b>Operating Temperature</b>	• -30°C to 50°C
<b>LED Count</b>	• 12 x 3W LED's		

**FLASH PATTERNS**

No.	Flash Pattern
1	• Rotating (default)
2	• Simulated rotating
3	• Full flashing (double flash)
4	• Full flashing (quad flash)
5	• Full flashing (single flash)

**DIMENSIONS**

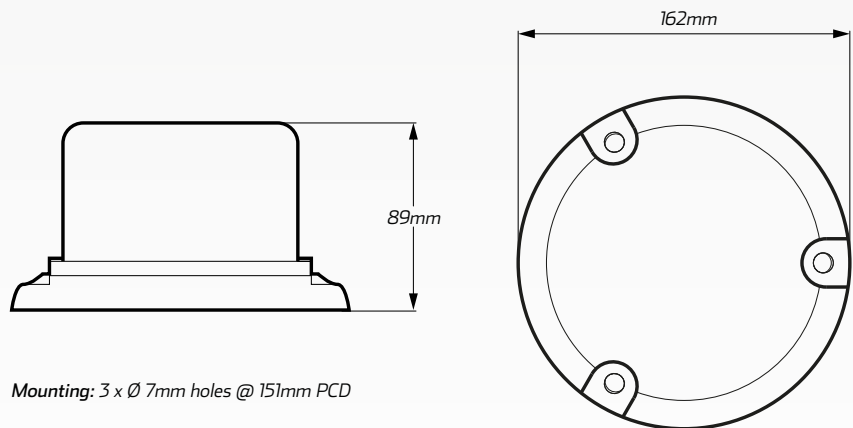

Mounting: 3 x Ø 7mm holes @ 151mm PCD