



Class 1 Amber/Blue LED Rotating Beacon
#103800C

www.ionnic.com

DESCRIPTION

Multi-volt (12-24V) Class 1 rated aerodynamic LED beacon. Features 3 different colour modes (amber / blue / dual colour - amber/blue). 12 different flash patterns in single colour mode and 5 in dual colour mode. Polycarbonate lens and aluminium base construction making this beacon rugged.

Environmentally sealed IP67 rated, dust and water protection. The 103 beacon series are synchronize-able with other 103 & 106 series. Complies to ECE R10. 3 bolt mounts (optional magnetic mount - A600VMK).



5 Year LED warranty

TECHNICAL SPECIFICATIONS

Voltage	• 12 - 24 Volt	Mounting	• 3 bolt mount
Current Draw	• 3.2A @ 12 Volt	Colour	• Amber/Blue
IP Rating	• IP67 rated	Dimensions	• 165mm (D) x 64mm (H)
Lens Material	• Polycarbonate lens	Flash Patterns	• 12 single mode / 5 dual mode
Base Material	• Aluminium base	Operating Temperature	• -30°C to 50°C
LED Count	• 18 x 3W LED's	Approvals	• ECE R10

FLASH PATTERNS

Flash Colour	Flash Pattern
	• 12 Amber: flash patterns (controlled individually)
	• 12 Blue: flash patterns (controlled individually)
	• 5 Amber/blue: flash patterns (controlled individually)

DIMENSIONS

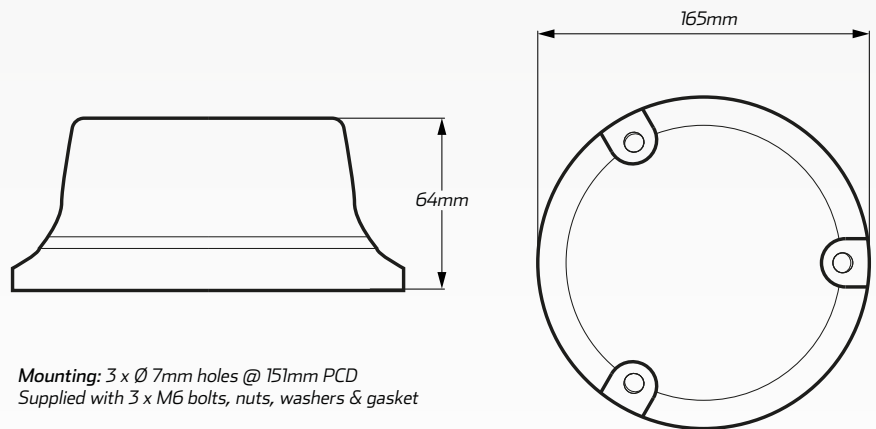

Mounting: 3 x Ø 7mm holes @ 151mm PCD
Supplied with 3 x M6 bolts, nuts, washers & gasket