



12V Stop/Tail  
& Indicator Lamp  
#149BARLP2

www.ledautolamps.com

### DESCRIPTION

LED Autolamps, low profile 12V stop/tail & indicator lamp with built-in reflector & horizontal mount license plate lamp.

Equipped with 12 (8 lamp & 4 license plate lamp) high powered LED's. Pre-wired with a 400mm cable. Comes in a twin blister pack that includes the left & right side lamp. ECE approved. IP67 rated.

5 year manufacturer warranty.

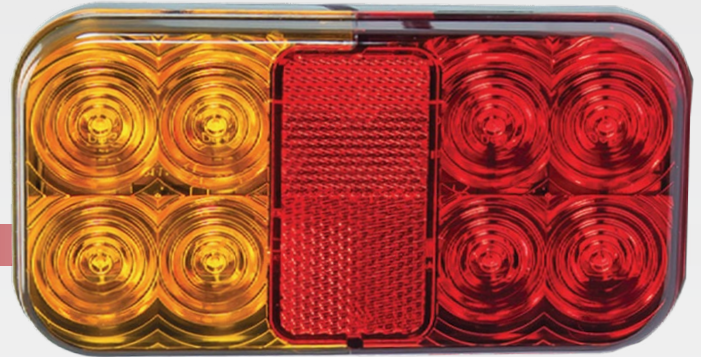

12V

ECE  
COMPLIANT

IP67

5 YEAR WARRANTY

### FEATURES

- Low profile stop/tail & indicator lamp with a built-in reflector
- Features a horizontal mount license plate lamp
- Equipped with 12 LED's (8 lamp + 4 license plate lamp)
- Pre-wired with a 400mm cable
- Comes in a twin blister pack (includes 2 lamp)
- ECE approved
- Waterproof up to IP67 rated
- 5 year manufacturer warranty



### TECHNICAL SPECIFICATIONS

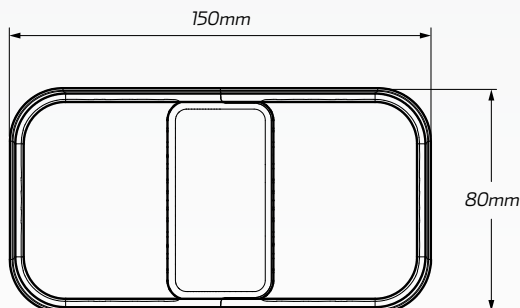
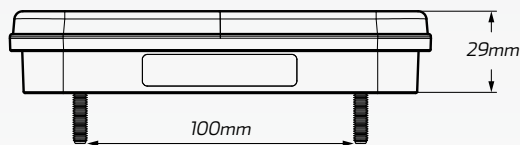

<b>Voltage Range</b>	• 12 Volt
<b>LED Count</b>	• 8 + 4 (license plate lamp) LED's
<b>Function</b>	• Stop/tail & indicator with reflector
<b>Current Draw</b>	• Stop: 0.05A @ 13.8V • Tail: 0.07A @ 13.8V • Indicator: 0.08A @ 13.8V
<b>Cable Length</b>	• 400mm cable
<b>Dimensions</b>	• 80mm H x 150mm W x 29mm D
<b>Approvals</b>	• Stop/tail: ECE R1-S1-E9-02.11712 • Indicator: ECE 2a-E9-01.11712 • License: ECE L-E9-00.11712 • Reflector: ECE IA-E9-02.11712