



12V Submersible Stop / Tail & Indicator Lamp  
#209GARLP2

www.ledautolamps.com

**DESCRIPTION**

Fully submersible stop/tail & indicator combination lamp with license plate lamp and reflector. Sealed with stainless steel bolts making this lamp the perfect choice for boat trailers.

Pre-wired with 300mm cable and is dust & waterproof up to IP67 rating. Accepts 12V applications only. ADR approved.

5 year manufacturer warranty.



12V    ADR COMPLIANT    IP67    5 YEAR WARRANTY

**FEATURES**

- Stop/tail & indicator lamp with license plate lamp & reflector
- Fully submersible, sealed with stainless steel bolts
- Accepts 12 Volt applications
- ADR approved
- Dust & waterproof up to IP67 rating
- Pre-wired with a 300mm cable
- 5 year manufacturer warranty



**TECHNICAL SPECIFICATIONS**

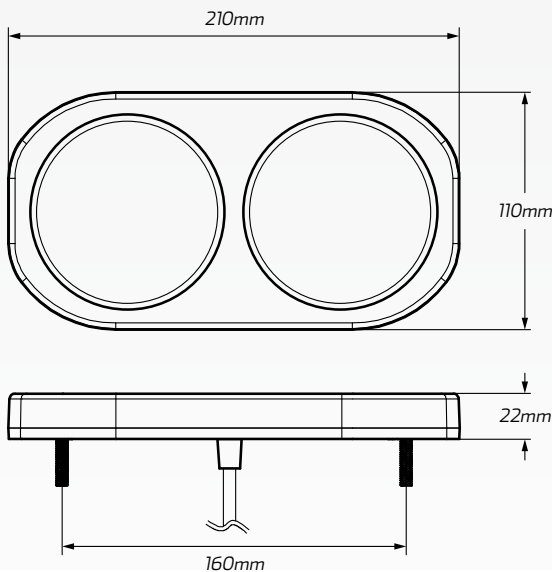

<b>Voltage Range</b>	• 12 Volt
<b>LED Count</b>	• 20 LED's (lamp), 3 LED's (license)
<b>Function</b>	• Stop/tail/indicator/reflector/license
<b>Current Draw</b>	• Stop: 0.117A @ 13.8V • Tail: 0.045A @ 13.8V • Reverse: 0.150A @ 13.8V
<b>Cable Length</b>	• 300mm cable
<b>Dimensions</b>	• 110mm H x 210mm W x 22mm D
<b>Approvals</b>	• Stop/tail: ADR 49/00 CRN 48974 • Indicator: ADR 6/00 2a CRN 48972 • Reflector: ADR 47/00 CRN 48973 • License: ADR 48/00 CRN 49550