



**Boat Trailer
Stop/Tail/Ind Lamp**
#210BARLP2-10MB

www.ledautolamps.com

DESCRIPTION

12 Volt stop/tail/indicator lamp with reflector.
Lens free design & fully submersible, suitable for boat trailer.
Features an in-built license plate lamp. IP68 rated weatherproof protection and ECE Australian road approval.



FEATURES

- Stop/tail/indicator with reflector
- Voltage input: 12 Volt only
- Features a lens free design & in-built license plate lamp
- ECE Australia Road Approved
- Fully submersible, perfect for boat trailer applications
- Pre-wired with a 10m cable
- Waterproof up to IP68 rating
- 10 year manufacturer warranty

TECHNICAL SPECIFICATIONS

Dimensions

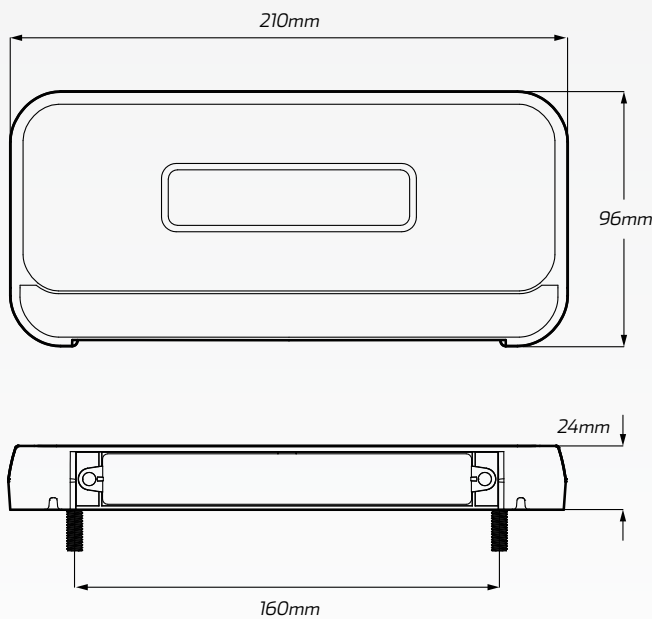

Voltage Range	• 12 only
Function	• Stop/tail/indicator with built in reflector & license plate lamp
LED Count	• 26 x tail, 30 x stop, 30 x indicator, 8 x license
Cable	• 10 metre pre-wired cable
IP Rating	• IP68 rated
Base Material	• Polycarbonate base
Fittings Material	• Stainless steel fittings
Dimensions	• 210mm L x 96mm W x 24mm D
Current Draw	• Stop: 0.17A @ 13.5V • Tail: 0.09A @ 13.5V • Indicator: 0.12A @ 13.5V
Approvals	• Stop/tail: ECE E9*148R00/02*1184*00 • Indicator: ECE E9*148R00/02*1184*00 • License: ECE E9*148R00/02*1184*00 • Reflector: ECE E9*150R00/02*1184*00 • Stop/Tail/Ind/Lic/Ref: CTA-060242
Warranty	• 10 year manufacturer warranty