

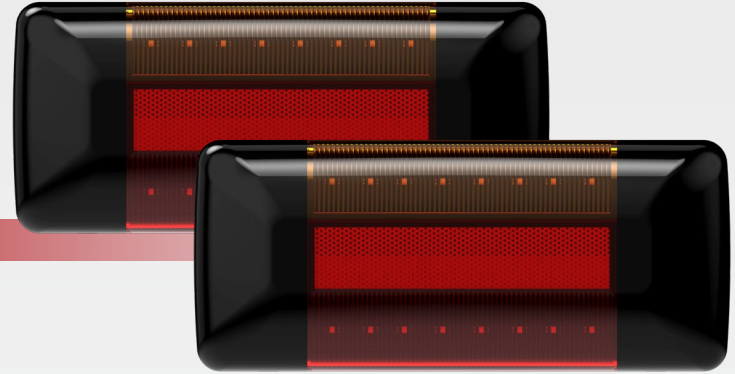

**LED Stop/Tail/Ind
With Reflector Lamp**
#223BARM2

www.ledautolamps.com



5 YEAR WARRANTY

DESCRIPTION

12-24 Volt stop/tail & indicator with reflector lamp.
Features an in-built reflex reflector, easy mounting design, IP67 rated water & dust protection and ADR Australian road approval. Equipped with rugged PMMA acrylic lens & ABS base.
5 year manufacturer warranty. Twin blister pack.

FEATURES

- 2 x Stop/tail & indicator lamp with reflex reflector
- Twin blister pack. Includes 2 light per blisters, ready to use
- Multivolt input: 12-24 Volt
- ADR Australian Road Approved
- Powered by 16 high intensity LED's
- Multi-position mounting points
- Rugged PMMA acrylic lens & ABS base
- Pre-wired with a 300mm cable
- Water & dustproof up to IP67 rating
- 5 year manufacturer warranty

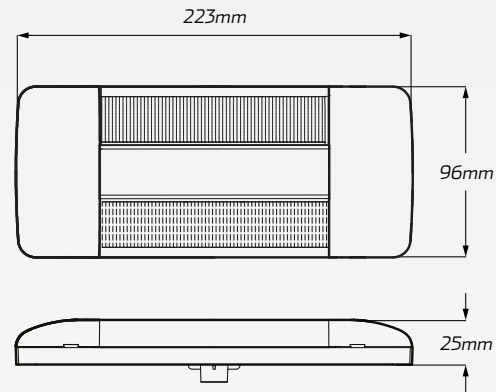

TECHNICAL SPECIFICATIONS

Voltage Range	• 12 - 24 Volt
Function	• Stop/tail/ & indicator with reflector lamp
LED Count	• 16 LED's
IP Rating	• IP67 rated
Cable	• 300mm pre-wired cable
Current Draw	• Stop: 0.15A @ 13.8V / 0.10A @ 28V • Tail: 0.01A @ 13.8V / 0.04A @ 28V • Indicator: 0.18A @ 13.8V / 0.25A @ 28V

Lens Material	• PMMA Acrylic lens
Base Material	• ABS base
Dimensions	• 223mm L x 96mm H x 25m D
Mounting Type	• Multi-position mounting points
Mounting Dimensions	• 154 - 199mm CTC
Approvals	• Stop/tail: ADR 50385 • Indicator: ADR 50423 • Reflector: ADR 50384