



12V 200 Amp
Continuous Duty Solenoid

Cole Hersee Co. #24143B

www.colehersee.com.au

DESCRIPTION

12V, 200 Amp continuous duty solenoid with insulated earth stud.
200 Amp make, 200 Amp break.

FEATURES

- Continuous duty solenoid
- SPST normally open (one circuit) OFF/ON
- Plated steel housing, hexnuts and washers included
- 4 stud, insulated earth stud
- Mount with brand cap facing "down"
- 200 Amp continuous, 600 Amp inrush
- Silver contacts

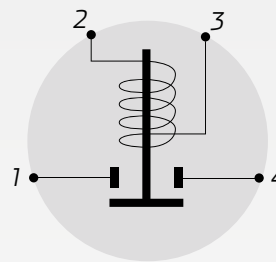
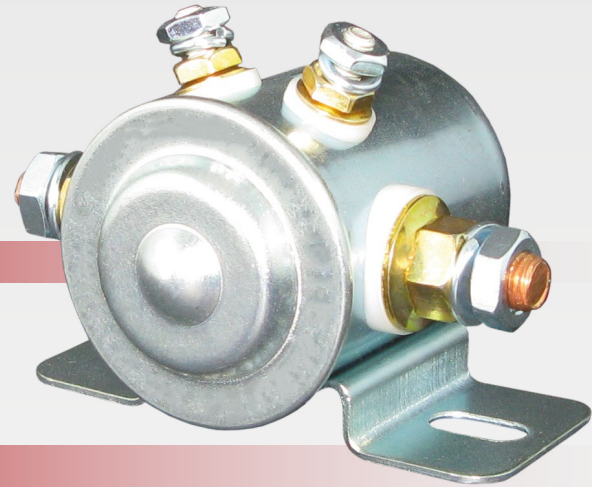

ELECTRICAL SCHEMATIC

Caution: never unscrew the inner hexnuts on the studs. These keep the stud and inner wiring in place.

TECHNICAL SPECIFICATIONS

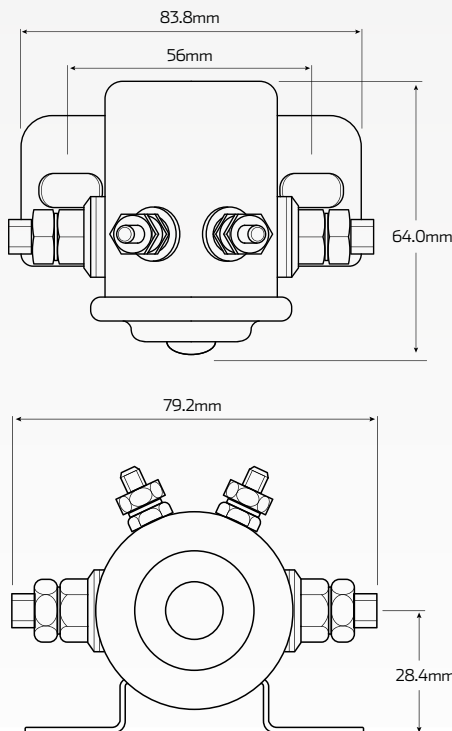

Voltage	• 12 Volt DC
Amperage	• 200 Amp continuous
Circuitry	• Single-Pole, Single-Throw (SPST)
Contacts	• Normally Open (NO)
Housing Material	• Plated steel
Contact Terminals	• Silver
Battery Terminals	• 5/16" - 24 threads
Coil Studs	• 10 - 32" threads
Insulated / Grounded	• Insulated
Operating Temperature	• -40°C to 85°C
Bracket Mounting Holes	• 7.9mm x 15.1mm, 56.0mm CTC