



Stop/Tail, Ind
& Reverse Lamp
#250ARWM

www.ledautolamps.com



DESCRIPTION

12-24 Volt stop/tail, indicator & reverse lamp with reflector. Features diamond lens pattern for greater visibility.

Pre-wired with 400mm cable. ECE approved. IP67 rated. Rugged construction with hardened acrylic lens and ABS base.

5 year manufacturer warranty.

12V
24V

ECE
COMPLIANT

IP67

5 YEAR WARRANTY

FEATURES

- Stop/tail, indicator & reverse combination lamp
- Equipped with a built-in reflector
- Multivolt: accepts 12/24 Volt applications
- Diamond lens pattern, equipped with 33 LED's
- Pre-wired with a 400mm cable
- Extremely rugged with hardened acrylic lens & ABS base
- ECE approved
- Dust & waterproof rated up to IP67 rating
- 5 year manufacturer warranty

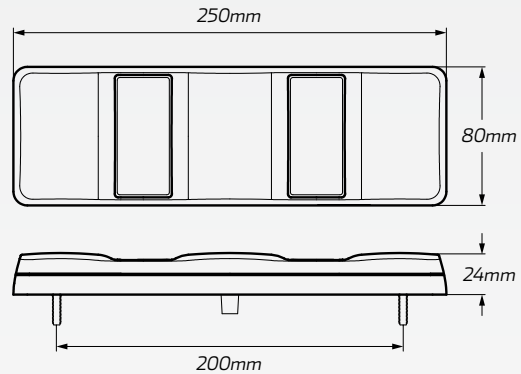

TECHNICAL SPECIFICATIONS

Voltage Range	• 12 - 24 Volt
LED Count	• 33 LED's
Function	• Stop/tail, indicator & reverse with reflector
Current Draw @ 13.8V	<ul style="list-style-type: none"> • Stop: 0.11A • Tail: 0.02A • Ind: 0.16A • Rev: 0.24A
Current Draw @ 28V	<ul style="list-style-type: none"> • Stop: 0.07A • Tail: 0.02A • Ind: 0.09A • Rev: 0.13A
IP Rating	• IP67 rated

Lens Material	• Hardened acrylic
Base Material	• ABS base
Cable	• Pre-wired 400mm cable
Dimensions	• 250mm W x 80mm H x 24mm D
Warranty	• 5 year manufacturer warranty
Approvals	<ul style="list-style-type: none"> • Stop/tail: ECE R1-S1-E9-02.6461 • Indicator: ECE 2a-E9-01.6461 • Reverse: ECE AR-E9-00.6461 • Reflector: ECE 1a-E9-02.6461