



**LED Stop/Tail, Ind
& Reverse Lamp**
#275GARWM

www.ledautolamps.com



12V
24V

ADR
COMPLIANT

IP67

5 YEAR WARRANTY

DESCRIPTION

Multivolt LED stop/tail, indicator & reverse lamp with built-in reflector. Incredibly rugged hexagonal patterned PMMA lens and ABS base. IP67 dust & waterproof rated. ADR approved. Lifetime manufacturer warranty.

FEATURES

- LED stop/tail, indicator & reverse lamp
- Low profile design lamp with hexagonal lens pattern
- Multivolt, accepts 12 / 24 Volt inputs
- Hexagonal lens pattern
- PMMA lens and ABS base material
- Powered by 72 high powered LED's
- Pre-wired with a 200mm cable
- ADR approved
- Waterproof up to IP67 rated
- 5 year manufacturer warranty

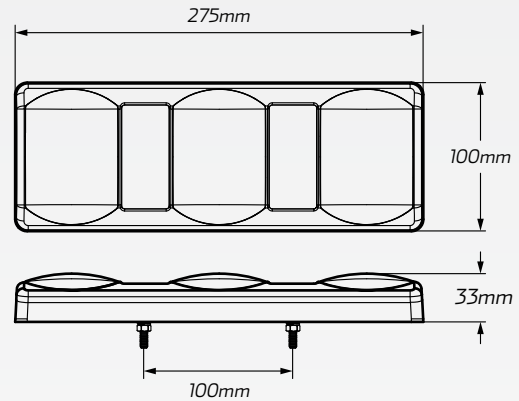

TECHNICAL SPECIFICATIONS

Function	• Stop/tail, indicator & reverse LED lamp	Lens Material	• PMMA lens
Voltage Range	• 12 - 24 Volts	Base Material	• ABS base
LED Count	• 72 LED's	Cable	• 200mm cable
Current Draw	<ul style="list-style-type: none"> • Stop: 0.23A @ 13.8V / 0.12A @ 28V • Tail: 0.04A @ 13.8V / 0.04A @ 28V • Indicator: 0.22A @ 13.8V / 0.12A @ 28V • Reverse: 0.16A @ 13.8V / 0.09A @ 28V 	Approvals	<ul style="list-style-type: none"> • Stop/tail: ADR 49/00 CRN 43223 • Indicator: ADR 6/00 2a CRN 43221 • Reverse: ADR 1/00 CRN 43222 • Reflector: ADR 02 1A CRN 1472
Dimensions	• 275mm W x 100mm H x 33mm D	IP Rating	• IP67 rated
Mounting	• 100mm centre to centre	Warranty	• 5 year manufacturer warranty