



12-24V Stop/Tail
& Reverse Lamp
#280RWM

www.ledautolamps.com

DESCRIPTION

High intensity stop/tail & reverse lamp.
Multivolt, accepts 12-24 Volt inputs. ECE road approved.

Features a rugged individually replaceable lenses, allowing the ease of maintenance and use of other functions should it be required. IP67 water and dust protection. Pre-wired with a 400mm cable.

5 year manufacturer warranty.



5 YEAR WARRANTY

FEATURES

- Stop/tail & reverse lamp
- Features individually replaceable lens
- Multivolt: accepts 12-24 Volt input voltage
- Equipped with 24 LED's (12/lens)
- Surface mount, pre-wired with a 400mm cable
- ECE approved
- Waterproof up to IP67 rated
- 5 year manufacturer warranty

REPLACEMENT LED'S



P/N. 280WM



P/N. 280RM



P/N. 280AM

TECHNICAL SPECIFICATIONS

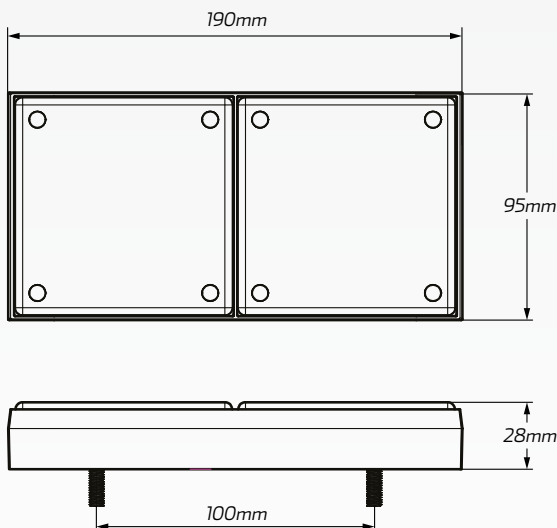

Voltage Range	• 12-24 Volt
LED Count	• 24 LED's
Function	• Stop/tail & reverse lamp
Current Draw	• Stop: 0.17A @ 13.8V / 0.10A @ 28V • Tail: 0.01A @ 13.8V / 0.02A @ 28V • Reverse: 0.20A @ 13.8V / 0.13A @ 28V
Cable Length	• 400mm cable
Dimensions	• 95mm H x 190mm W x 28mm D
Approvals	• Stop/tail: ECE R1-S1-E9-02.11545 • Reverse: ECE AR-E9-00.1207