

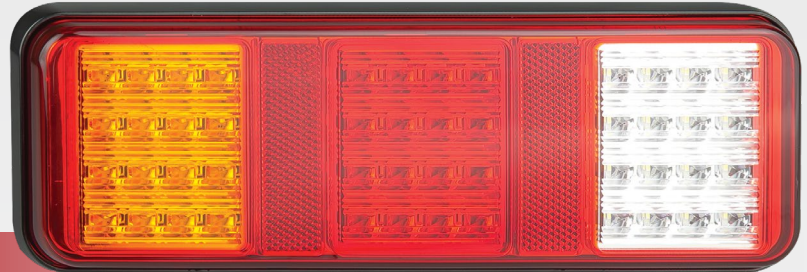

**LED Stop/Tail,
Ind & Reverse Lamp**
#283ARWM

www.ledautolamps.com



DESCRIPTION

12-24 Volt stop/tail, indicator & reverse combination lamp. Features a removable bolt/screw on bracket for ease of installation. Powered by 48 high powered LED's & pre-wired with 300mm cable. IP67 rated. ADR approved. 5 year manufacturer warranty.



5 YEAR WARRANTY

FEATURES

- Stop/tail, indicator & reverse combination lamp
- Bolt/screw on removable mounting bracket
- Multi-volt, accepts 12-24 Volt applications
- ADR approved
- Dust & waterproof up to IP67 rating
- Pre-wired with a 300mm sheathed cable
- 5 year manufacturer warranty



TECHNICAL SPECIFICATIONS

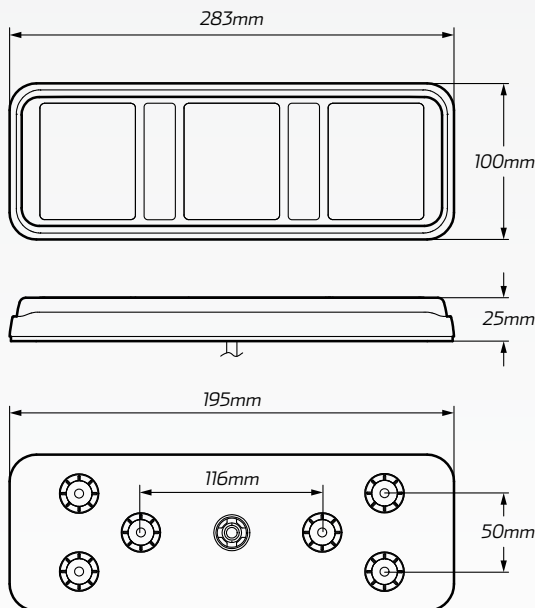

Voltage Range	• 12 - 24 Volt
LED Count	• 48 LED's
Function	• Stop/tail, indicator & reverse lamp
Current Draw	<ul style="list-style-type: none"> • Stop: 0.24A @ 13.8V / 0.12A @ 28V • Tail: 0.03A @ 13.8V / 0.02A @ 28V • Indicator: 0.27A @ 13.8V / 0.14A @ 28V • Reverse: 0.17A @ 13.8V / 0.10A @ 28V
Cable Length	• 300mm cable
Dimensions	• 100mm H x 283mm W x 25mm D
Approvals	<ul style="list-style-type: none"> • Stop: ADR 49/00 CRN 49520 • Tail: ADR 49/00 CRN 49534 • Indicator: ADR 6/00 Cat2a CRN 49536 • Reverse: ADR 1/00 CRN 49519 • Reflector: ADR 47/00 CRN 50260