

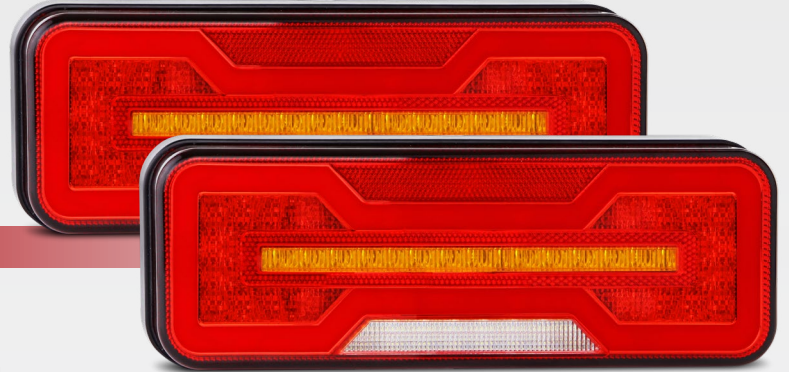

LED Stop/Tail/Ind & Reverse Lamp

#284ARWM-2

www.ledautolamps.com



5 YEAR WARRANTY

DESCRIPTION

10-30 Volt stop/tail/indicator & reverse lamp. Twin blister pack.
 Exclusive LED Autolamps design. Features diffused tail function, sequential indicator, IP67 rated weatherproof protection and ECE Australian road approval. Equipped with polycarbonate lens & base.
 5 year manufacturer warranty.

FEATURES

- Blister packed: Includes 2 x stop/tail/indicator & reverse lamp
- Multivolt input: 10-30 Volt
- Exclusive LED Autolamps design
- ECE Australian Road Approved
- Rugged polycarbonate lens & polycarbonate base
- Pre-wired with a 280mm cable
- Waterproof up to IP67 rating
- Diffused tail function & sequential indicator
- Surface mount
- 5 year manufacturer warranty

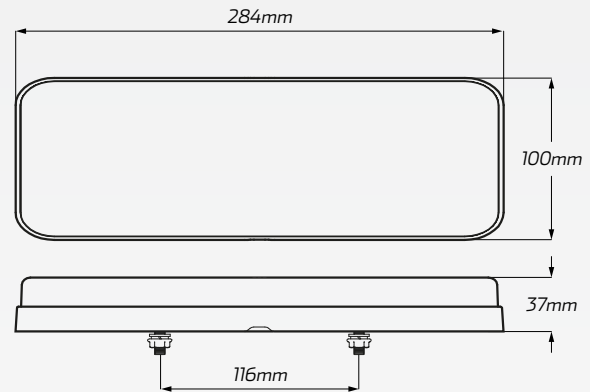

TECHNICAL SPECIFICATIONS

Voltage Range	• 10 - 30 Volt	Lens Material	• Polycarbonate lens
Function	• Stop/tail/ind & reverse lamp	Base Material	• Polycarbonate base
Features	• Sequential indicator & diffused tail function	Dimensions	• 284mm L x 100mm H x 37mm D
IP Rating	• IP67 rated	Mounting Type	• Surface Mount
Cable	• 280mm pre-wired cable	Mounting Dimensions	• 116mm CTC
Current Draw	<ul style="list-style-type: none"> • Stop: 0.18A @ 13.8V / 0.08A @ 28V • Tail: 0.14A @ 13.8V / 0.07A @ 28V • Indicator: 0.30A @ 13.8V / 0.15A @ 28V • Reverse: 0.14A @ 13.8V / 0.08A @ 28V 	Approvals	<ul style="list-style-type: none"> • Stop/tail: ECE E9*7R02/27*22553*00 • Indicator: ECE E9*6R01/28*22553*00 • Reverse: ECE E9*23R00/22*22553*00 • Reflector: ECE E9*3R02/7*22553*00