



**LED Stop/Tail /Ind
& Reverse Lamp**
#385ARWM-2

www.ledautolamps.com



5 YEAR WARRANTY

DESCRIPTION

12-24 Volt stop/tail & reverse lamp. Twin blister pack.
Features diffused tail function, sequential indicator, IP67 rated water & dust protection and ECE Australian road approval. Equipped with rugged PMMA acrylic lens & ABS base.
5 year manufacturer warranty.

FEATURES

- 2 x Stop/tail/indicator & reverse lamp with sequential indicator
- Multivolt input: 12-24 Volt
- ECE Australian Road Approved
- Powered by 112 high intensity LED's
- Surface mount
- Rugged PMMA acrylic lens & ABS base
- Pre-wired with a 400mm cable
- Waterproof up to IP67 rating
- Diffused tail function
- 5 year manufacturer warranty

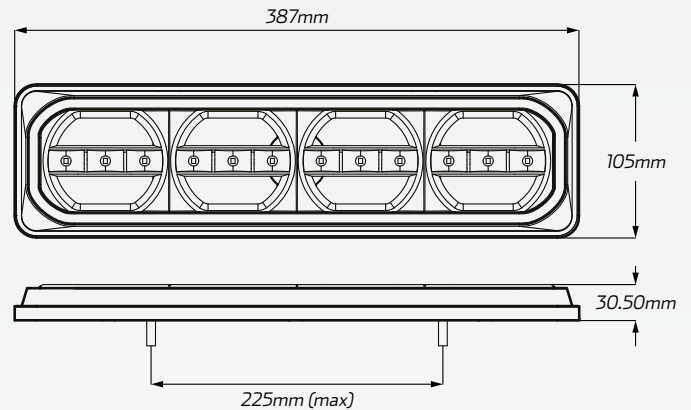

TECHNICAL SPECIFICATIONS

Voltage Range	• 12 - 24 Volt
Function	• Stop/tail/ind & reverse lamp
LED Count	• 112 LED's
IP Rating	• IP67 rated
Cable	• 400mm pre-wired cable
Current Draw	<ul style="list-style-type: none"> • Stop: 0.23A @ 13.8V / 0.12A @ 28V • Tail: 0.57A @ 13.8V / 0.30A @ 28V • Indicator: 0.24A @ 13.8V / 0.14A @ 28V • Reverse: 0.37A @ 13.8V / 0.19A @ 28V

Lens Material	• PMMA Acrylic lens
Base Material	• ABS base
Dimensions	• 387mm L x 105mm H x 30.50m D
Mounting Type	• Surface Mount
Mounting Dimensions	• 185-225mm CTC
Approvals	<ul style="list-style-type: none"> • Stop/tail: ECE E9*7R02/27*23586*00 • Indicator: ECE E9*6R01/29*23586*00 • Reverse: ECE E9*23R00/22*23586*00