

NARVA® Ultima 225 LED Combination Driving Light Kit
#71705

www.narva.com.au

DESCRIPTION

9-33V Enhanced Optic Driving Lights - 5,700 Lumens ea. Premium styled driving lights utilising the latest in enhanced free form 'Optic Drive™' L.E.D technology to capture and harness the light output for maximum performance.

Specifically designed to endure the harshest Australian conditions, they produce a H.I.D like output with all the benefits of L.E.D. The Enhanced Optic range transform everyday 4x4s and SUVs into luxurious escape vehicles.

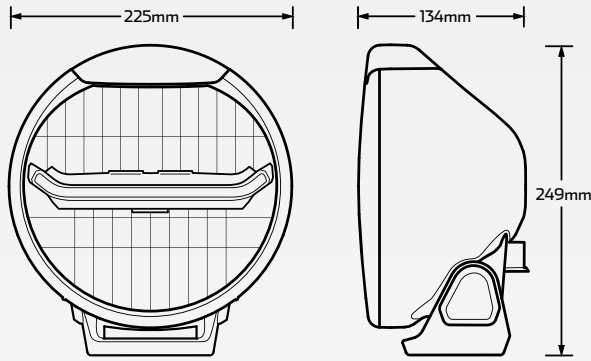

KIT INCLUDES:

- 1 x Broad Beam LED Driving Light
- 1 x Pencil Beam LED Driving Light
- 1 x Plug 'n' Play Wiring Harness Kit

COMBO
BROAD & PENCIL

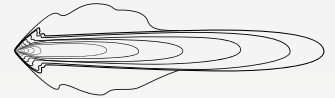

BEAM COVERAGE

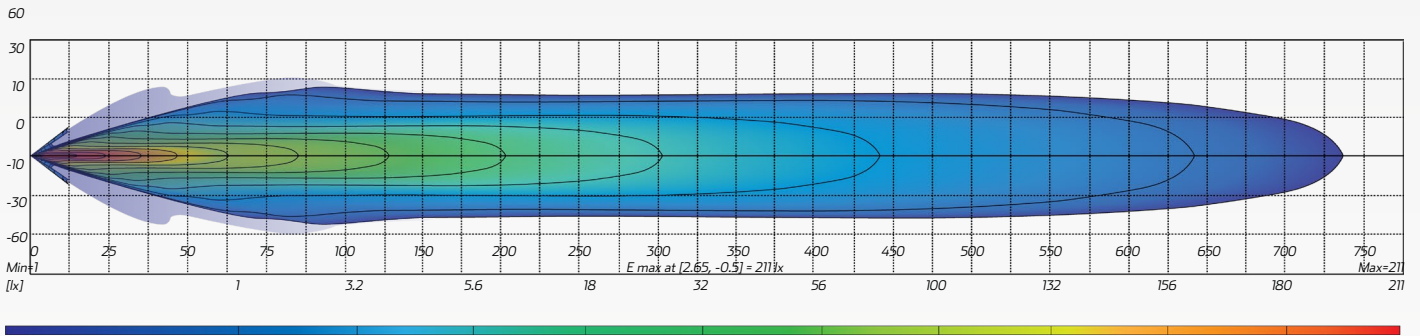

TECHNICAL SPECIFICATIONS

Voltage	• 9 - 33 Volt - 45W	Beam Coverage	• Pencil Beam & Broad Beam
IP Rating	• IP67 Rated	Colour Temperature	• 5000 K
Lumens	• Effective - 2,500lm / Raw - 5,700lm	Accessories	• 2 x Polycarbonate Lens Protector • 1 x Stainless Steel Mount • 1 x Wiring Harness Kit
LED Count	• 3 x 15W XHP50.2 CREE LED's	Dimensions	• 225mm L x 249mm H x 134mm D
Lens	• Polycarbonate Lens		