

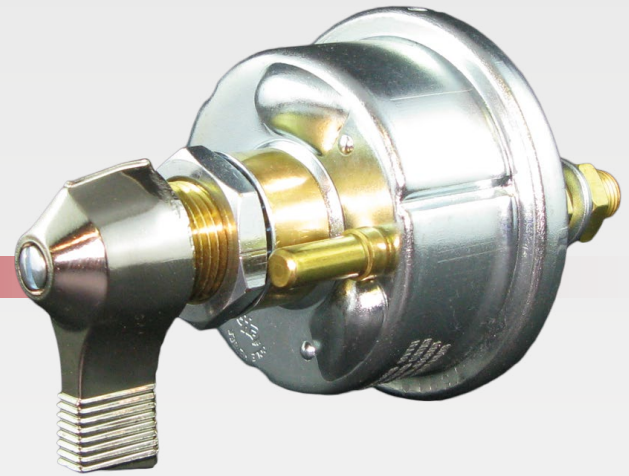

Lever Type Isolator Switch with Indexing Post

Cole Hersee Co. #75910

www.colehersee.com.au



DESCRIPTION

DPST on/off battery isolator switch with indexing post.
6-36V, 125A continuous, 1000A intermittent.
Features silver contacts with chrome lever, weather resistant O'ring seal on mounting shaft. 3/4" mounting stem. Small terminals 20A @ 12V.

FEATURES

- Disconnects the battery and the alternator or generator field
- Complies with BHP mining standards
- DPST configuration
- Silver contacts, chrome lever
- O-ring sealed for weather resistance
- Indexing pin aligns switch and prevents rotation
- Suits panel thickness to 6.5mm
- 20A continuous field terminal amperage
- Mounting stem 3/4" - 24 thread, L 13mm

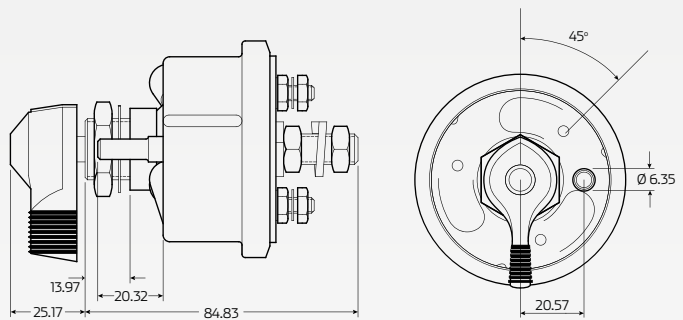

*All measurements are in mm

TECHNICAL SPECIFICATIONS

Voltage	• 6 - 36V multi-volt	Housing Material	• Steel plated casing, chrome lever
Maximum Amperage	• 1000A Intermittent	Field Studs Size	• 2 x studs 10 - 32
Continuous Amperage	• 125A continuous	Battery Studs Size	• 2 x studs 3/8" - 24
Field Terminals Amperage	• Field terminals 20A continuous	Stud Torque	• 4.4 to 7.4 ft lbs (6-10 Nm)
Configuration	• DPST	Operating Temperature	• -40°C to 85°C
Dimensions	• 110mm x 67mm Ø	Mounting Stem	• 3/4" - 24 thread, L 13mm
Contact Material	• Silver contacts	Weatherproof	• Yes, O-ring sealed