



**Class 1 Blue  
LED Rotating Beacon  
#7660A**

www.eccosafetygroup.com.au

**DESCRIPTION**

Class 1 LED rotating beacon with amber lens and 3 bolt mount. The 7660A uses a brush-less magnetic drive system to spin the reflector disk with minimum noise and drawbacks. Include 8 high intensity LED's and TIR optics rated at SAE class I.

UV resistant lens with a die-cast aluminium base, making this light rugged and abrasive resistant. Sealed up to IP67 rated withstanding up to 50°C operating temperature.

Suitable for heavy duty commercial, construction and agricultural vehicles.



**FEATURES**

- Class 1 LED rotating beacon
- 8 high intensity LED's with 125 RPM flash pattern
- High intensity LED hybrid technology (no gears/bulb wearing)
- Brush-less magnetic drive reflector spin system - lowers drawback risks and noise
- UV resistant lens, reducing the chance of cracking, fogging and abrasion.
- Die-cast aluminium base & IP67 rated dust and water protection
- Universal bolt mounting pattern
- 5 year manufacturer warranty

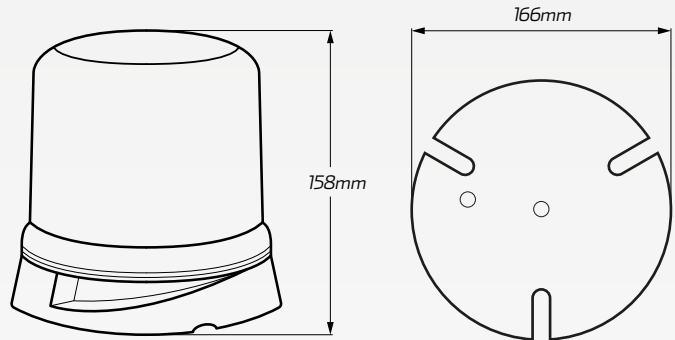

**TECHNICAL SPECIFICATIONS**

<b>Voltage</b>	• 12-24 Volt DC
<b>Max. Power</b>	• 26.6W @ 12 Volt DC
<b>Current Rating</b>	• 2.08 Amps @ 12 Volt DC
<b>LED Count</b>	• 8 high intensity LED's
<b>Lens Material</b>	• Polycarbonate
<b>Base Material</b>	• Die-cast aluminium
<b>Colour</b>	• Amber

<b>Flash Pattern</b>	• Rotate - 125 RPM
<b>Operating Temperature</b>	• -30°C to 50°C
<b>IP Rating</b>	• IP67 rated
<b>Mounting</b>	• 3 bolt mounting
<b>Dimensions</b>	• 166mm D x 158mm H
<b>Approvals</b>	<ul style="list-style-type: none"> <li>• SAE J845 Class I</li> <li>• CE, R10, R65, Cal. Title 13</li> <li>• RoHS</li> </ul>