

NARVA® Aerotech Slimline Mini LED
THE VISION TO GO FURTHER Magnetic Clear Amber Beacon
#85016AC

www.narva.com.au

DESCRIPTION

Aerotech slimline mini LED magnetic clear amber beacon. This LED beacon from Narva are engineered, designed & tested in Australia. Features a new design producing a brighter and more visible beacon, vibration resistant tested to ISO & military specifications, 6 selectable flash patterns & a day/night mode. IP67+69K dust & water protection.

Comes with 7 year manufacturer warranty.



Clear when not illuminated

FEATURES

- 10-80 Volt operation input. Synchronizable with up to 6 units
- Ultra bright uniform output, meets & exceed international standard
- Virtually unbreakable polycarbonate lens & base
- Optional day/night mode & up to 6 selectable flash patterns
- IP67+69K rated water & dust protection

FLASH PATTERNS

No.	Flash Pattern	No.	Flash Pattern
1.	• Double flash (SAE/ECE TAZ)	4.	• Rotate
2.	• Ultra (alternating flash)	5.	• Quint
3.	• Ultra (cross flash)	6.	• Double rotate

DIMENSIONS

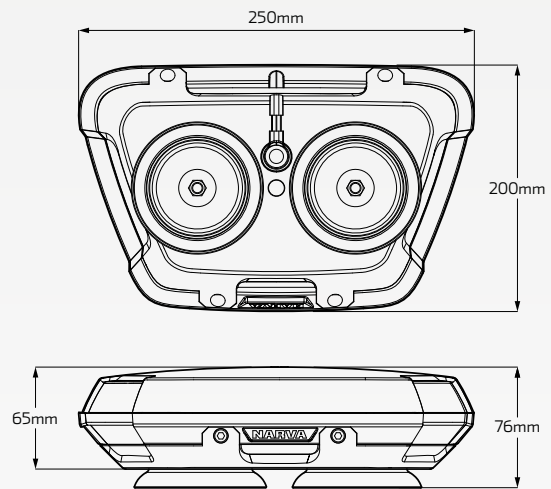

TECHNICAL SPECIFICATIONS

Input Voltage	• 10 to 80 Volt	Lens Material	• Polycarbonate lens
LED Count	• 54 x 1.5W high powered LED	Housing Material	• Polycarbonate base
Current Draw	• 3.5A (double flash) / 1.7A (rotate) @ 12V	Mounting	• Magnetic
IP Rating	• IP67+69K rated	Warranty	• 7 year manufacturer warranty
Flash patterns	• 6 selectable flash patterns	Approvals	• SAE Class 1 / Ca T13 • CISPR25 Class 3 • ECE R65 Class 2
Dimensions	• 250mm W x 200mm D x 76mm H		