

**NARVA®** Aerotech Slimline  
THE VISION TO GO FURTHER LED Amber Beacon  
#85017A

www.narva.com.au



**DESCRIPTION**

Aerotech slimline LED amber beacon. This LED beacon from Narva are engineered, designed & tested in Australia. Features a new design producing a brighter and more visible beacon, vibration resistant tested to ISO & military specifications, 6 selectable flash patterns & a day/night mode. IP67+69K dust & water protection. Comes with 7 year manufacturer warranty.

**FEATURES**

- 10-80 Volt operation input. Synchronizable with up to 6 units
- Ultra bright uniform output, meets & exceed international standard
- Virtually unbreakable polycarbonate lens & base
- Optional day/night mode & up to 6 selectable flash patterns
- IP67+69K rated water & dust protection

**FLASH PATTERNS**

No.	Flash Pattern	No.	Flash Pattern
1.	• Double flash (SAE/ECE TAZ)	4.	• Rotate
2.	• Ultra (alternating flash)	5.	• Quint
3.	• Ultra (cross flash)	6.	• Double rotate

**DIMENSIONS**

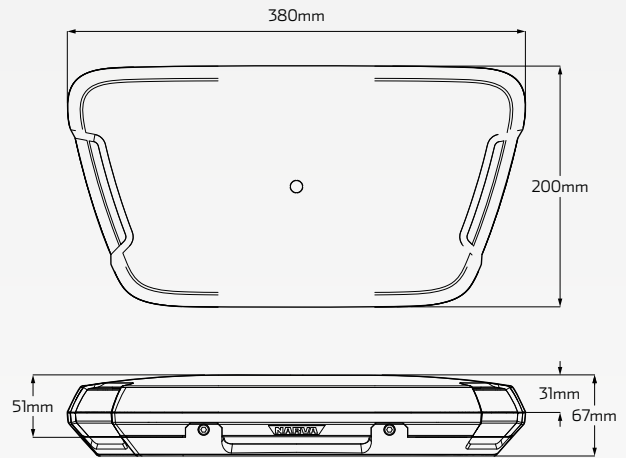

**TECHNICAL SPECIFICATIONS**

<b>Input Voltage</b>	• 10 to 80 Volt
<b>LED Count</b>	• 84 x 1.5W high powered LED
<b>Current Draw</b>	• 3.7A (double flash) / 2.1A (rotate) @ 12V
<b>IP Rating</b>	• IP67+69K rated
<b>Flash patterns</b>	• 6 selectable flash patterns
<b>Dimensions</b>	• 380mm W x 200mm D x 67mm H

<b>Lens Material</b>	• Polycarbonate lens
<b>Housing Material</b>	• Polycarbonate base & mounting cradle
<b>Mounting</b>	• Bolt on
<b>Warranty</b>	• 7 year manufacturer warranty
<b>Approvals</b>	• SAE Class 1 / Ca T13 • CISPR25 Class 3 • ECE R65 Class 2