

**NARVA®** Double Side Ind  
Lamp - Globe Type  
#85940

www.narva.com.au



**DESCRIPTION**

Double sided round indicator lamp.

Easy to install & replaced, allowing ease of maintenance and road safety. This lamp is powered by 1 x BA15s (not included). ADR/ECE approved. Replacement lens available.

**TECHNICAL SPECIFICATIONS**

<b>Voltage Range</b>	• 12/24 Volt (based of installed globe)
<b>Function</b>	• Indicator & park bullbar lamp
<b>Lens Colour</b>	• Amber
<b>Globe Type</b>	• 1 x BA15s (not included)
<b>Dimensions</b>	• 115mm dia x 47mm deep
<b>Mounting</b>	• Fitting bolt
<b>ECE Approvals</b>	• 15398
<b>ADR Approvals</b>	• 6/00 Cat 5

**DIMENSIONS**

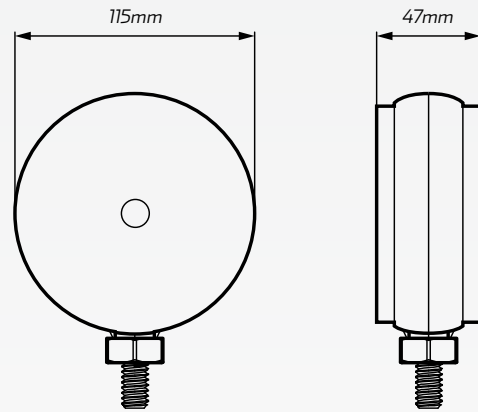

**PART NUMBER**

Part Number.	Qty	Function	Description
85940	1	• Dual indicator lamp	• Double sided indicator lamp. Takes 1 x BA15s globe (not included). ADR approved.
85945	1	• Replacement lens	• Replacement lens to suit 85945 lamp.