

**NARVA®** Stop/Tail, Ind & Reverse Lamp  
#86210

www.narva.com.au

**DESCRIPTION**

Bayonet globe powered stop/tail, indicator & reverse lamp. Equipped with rugged heavy duty metal bracket. Accepts both 12V & 24V bayonet globes. ECE/ADR approved. Replacement lens available. Globes not included.

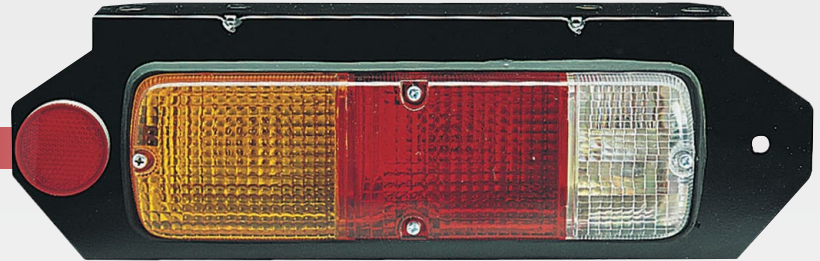

**FEATURES**

- Stop/tail, indicator & reverse lamp with reflector
- Equipped with a heavy duty metal bracket
- Powered by bayonet globes
- Suitable for 12/24V globe application
- Easy lens replacement when required
- ECE/ADR approved
- Bayonet globes not included

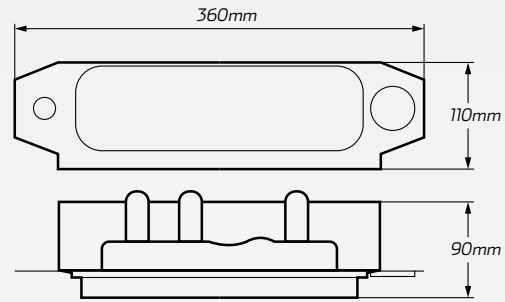

**TECHNICAL SPECIFICATIONS**

<b>Voltage Range</b>	• 12/24 Volt (based of installed globe voltage)	<b>Dimensions</b>	• 360mm x 110mm x 90mm
<b>Globe Type</b>	• Bayonet globe	<b>ECE Approvals</b>	• 15689, 15691, 15693
<b>Function</b>	• Stop/tail, indicator & reverse lamp	<b>ADR Approvals</b>	• 6/00 (cat 2a) • 1/00 • 49/00
<b>Features</b>	• Built-in reflector		

**PART NUMBER**

Part Number.	Quantity	Description
86210	• 1 combination lamp	• 1 x Bayonet globe powered stop/tail, indicator & reverse lamp with reflector. ECE/ADR approved.
86205	• 1 replacement lens	• 1 x Replacement lens to suit 86210.