

**NARVA**® 10-30V Stop/Tail & Indicator Lamp  
THE VISION TO GO FURTHER 93812BL

www.narva.com.au



**DESCRIPTION**

10-30 Volt stop/tail & indicator lamp. Features rugged polycarbonate lens & black mounting base. Pre-wired with 500mm cable and is environmentally sealed up to IP66 rating. Available in a individual or a twin blister pack (2 lights). 5 years manufacturer warranty.



**5 YEAR WARRANTY**

**FEATURES**

- 10-30V stop/tail & indicator lamp
- Equipped with a rugged polycarbonate lens
- Black mounting base (114mm CTC)
- Pre-wired with 500mm cable
- Dust and waterproof rated up to IP66 rating
- ADR approved (horizontal/vertical installation)
- Available in a individual or a twin blister pack (2 lights)

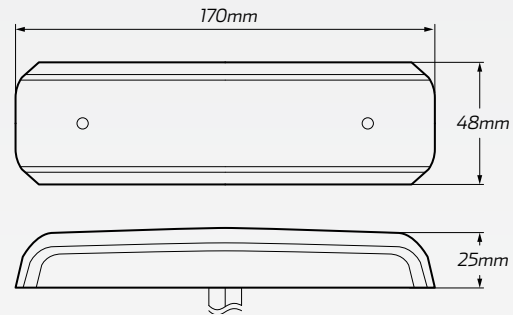

**TECHNICAL SPECIFICATIONS**

<b>Voltage Range</b>	• 10 - 30 Volt	<b>Lens</b>	• Polycarbonate lens
<b>Current Draw</b>	• Stop: 0.08A @ 10-30V • Tail: 0.02A @ 10-30V • Indicator: 0.08A @ 10-30V	<b>Dimensions</b>	• 48mm H x 170mm W x 25mm D
<b>Mounting</b>	• Surface mount (114mm CTC)	<b>Approvals</b>	• ADR 6/00 44211 (cat2a) • ADR 49/00 44214

**PART NUMBER**

Part Number.	Quantity	Wire Length	Description
93812BL	• 1 lamp	• 500mm cable	• LED stop/tail & indicator lamp with 500mm pre-wired cable. Blister pack.
93812BL2	• 2 lamps	• 500mm cable	• 2 x LED stop/tail & indicator lamp with 500mm pre-wired cable. Twin blister pack.