



12V Stop/Tail  
& Indicator Lamp  
#DB2

www.ledautolamps.com



12V

ECE  
COMPLIANT

IP67

2 YEAR WARRANTY

**DESCRIPTION**

Surface mount budget LED Autolamps stop/tail & indicator lamp with reflector. Features 8 x LED's with enhanced lens optics to provide maximum light output. ECE approved.

Suitable for 12V applications only. Equipped with 3M tapes for an easy mounting option. Waterproof rated up to IP67.

2 year manufacturer warranty.

**FEATURES**

- 12V stop/tail & indicator lamp with reflector
- Comes in a twin blister pack (2 lamps included)
- Equipped with 8 x LED's with enhanced lens optics
- 3M tape backing for easy mounting option
- Maximum light output in a low profile body
- ECE approved
- Waterproof up to IP67 rated
- 2 year manufacturer warranty



3M tape backing.

Please refer to ADR 13/00 for mounting instructions

**TECHNICAL SPECIFICATIONS**

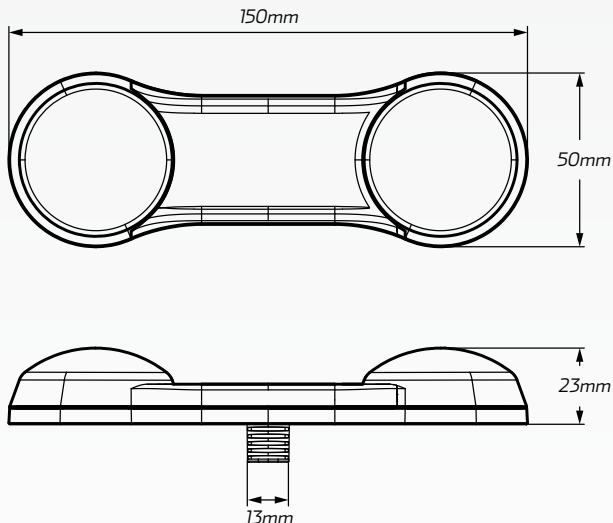

<b>Voltage Range</b>	• 12 Volt
<b>LED Count</b>	• 8 LED's
<b>Function</b>	• Stop/tail & indicator with reflector
<b>Current Draw</b>	• Stop: 0.65A @ 13.8V • Tail: 0.004A @ 13.8V • Indicator: 0.058A @ 13.8V
<b>Cable Length</b>	• 300mm cable
<b>Dimensions</b>	• 50mm H x 150mm W x 23mm D
<b>Approvals</b>	• Stop/tail: ECE 02-R1-S1.16451 • Indicator: ECE 01-2a.16451 • Reflector: ECE 02-1A.16451