



DuraLed® Amber  
Front Marker Lamp  
#H2051

www.hella.com



Clear lens when not illuminated.

**DESCRIPTION**

LED amber front marker lamp that features increased chemical resistance acrylic lens and curved design to further reduce possible impact damage from stones and tie-downs.

Suitable for 12 - 24 Volt application & comes with black mounting bracket. Pre-wired with twin sheathed cables. IP6K6 and IP6K7 rated dust and moisture resistant. ADR approved.

**FEATURES**

- Multivolt: 12 - 24 Volt DC
- Compact & easy to install
- Dust & moisture resistant - IP6K6 & IP6K7 rated
- ADR 49/00 approved
- Acrylic lens for increased chemical resistance
- Curved design to reduce possibility of impact damage
- Clear lens when not illuminated.
- Available in a bulk pack of 4

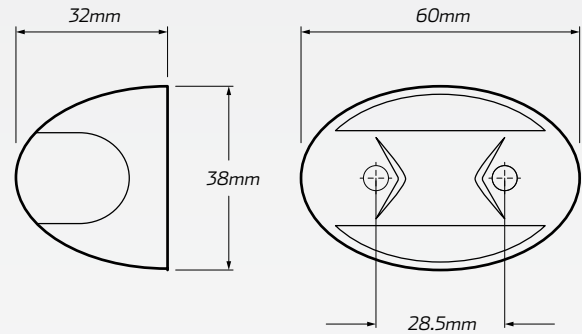

**TECHNICAL SPECIFICATIONS**

<b>Voltage Range</b>	• 12 - 24 Volt	<b>Dimensions</b>	• 38mm H x 60mm W x 32mm D
<b>Wattage</b>	• 0.4 Amps @ 12V DC / 0.8Amps @ 24V DC	<b>Wiring</b>	• Pre-wired twin sheath
<b>Mounting</b>	• Surface mount	<b>Approval</b>	• ADR 49/00 • CRN: 25032
<b>IP Rating</b>	• IP6K6 & IP6K7 (dust & moisture)		

**PART NUMBER**

Part Number.	Quantity	Cable Length	Description
H2051	• 1 lamp	• 500mm twin sheathed cable	• LED amber front marker lamp with 500mm twin sheathed cable
H2051BULK	• 4 lamps	• 2.5m twin sheathed cable / lamp	• 4x LED amber front marker lamp with 2.5m twin sheathed cable