



**DuraLed® Red
Rear Marker Lamp**
#H2307

www.hella.com



Clear lens when not illuminated.

DESCRIPTION

LED red rear marker lamp that features increased chemical resistance acrylic lens and curved design to further reduce possible impact damage from stones and tie- downs.

Suitable for 12 - 24 Volt application & comes with black mounting bracket. Pre-wired with twin sheathed cables. IP6K6 and IP6K7 rated dust and moisture resistant. ADR approved.

FEATURES

- Multivolt: 12 - 24 Volt DC
- Compact & easy to install
- Dust & moisture resistant - IP6K6 & IP6K7 rated
- ADR 49/00 approved
- Acrylic lens for increased chemical resistance
- Curved design to reduce possibility of impact damage
- Clear lens when not illuminated.
- Available in a bulk pack of 4

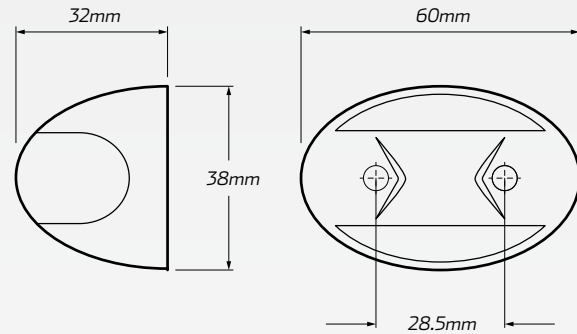

TECHNICAL SPECIFICATIONS

Voltage Range	• 12 - 24 Volt	Dimensions	• 38mm H x 60mm W x 32mm D
Wattage	• 0.4 Amps @ 12V DC / 0.8Amps @ 24V DC	Wiring	• Pre-wired twin sheath
Mounting	• Surface mount	Approval	• ADR 49/00 • CRN: 25009 • ECE E4 02 7574
IP Rating	• IP6K6 & IP6K7 (dust & moisture)		

PART NUMBER

Part Number.	Quantity	Cable Length	Description
H2307	• 1 lamp	• 500mm twin sheathed cable	• LED red rear marker lamp with 500mm twin sheathed cable
H2307BULK	• 4 lamps	• 2.5m twin sheathed cable / lamps	• 4x LED red rear marker lamp with 2.5m twin sheathed cable