



## 50W High Output LED Amber Beacon

#HM500ADIR

www.hella.com



### DESCRIPTION

Multi-volt 12-30 Volt DC, 50W high output twin LED amber beacon. Extremely rugged suitable for heavy duty applications in the harshest environments. Equipped with Helio-Shield™, a robust high visibility polycarbonate lens for improved daylight/dusty warning signal visibility.

User selectable rotating or quad flash patterns. Die-cast alloy base, corrosion and shock/impact resistant (up to 200G). IP6K5 rated dust and water protection. Overheat & reverse polarity protected. 3 bolt mount.

A suitable beacon for heavy commercial & dusty surface mining operations.

### FEATURES

- SAE J845 Class 1 LED amber beacon
- Multi-volt 12-30 Volt DC, 50W max current input
- User selectable rotating or quad flash pattern options
- Helio-Shield™ polycarbonate lens for ambient light suppression
- Shock/impact resistant die-cast alloy base.
- O-ring sealed, dust and water protection (IP6K5 rated)
- Overheat & reverse polarity/short circuit protection.
- Pre-wired double insulated 2 metres cable

### FLASH PATTERNS

Flash Pattern	Flash Rate
Rotating	• 80 cycles/min
Flash	• 72RPM (quad flash)

### TECHNICAL SPECIFICATIONS

Voltage	• 12-30 Volt DC
Power Consumption	• 50W max
Lens Material	• Helio-Shield™ polycarbonate lens
Base Material	• Die-cast alloy base
Colour	• Amber
Operating Temperature	• -20°C to 50°C
IP Rating	• IP6K5 rated
Mounting	• 3 bolt mounting
Dimensions	• 187mm D X 132mm H
Approvals	• SAE J845 Class 1

### DIMENSIONS

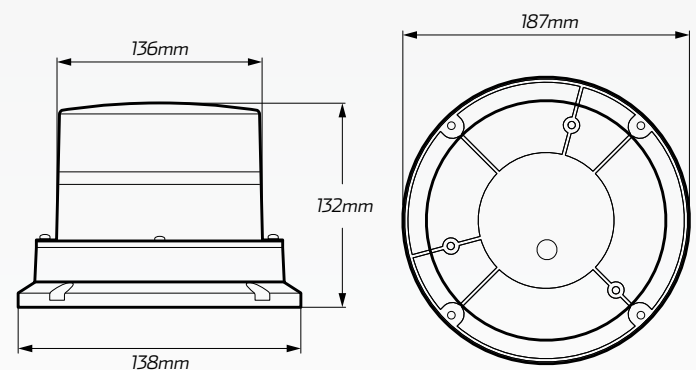

Mounting: 3 x Ø4mm equispaced on PCD130  
Pre-wired 2 metres double insulated cable.