



HTX2
Hybrid Driving Light
#HTXMK2

www.lightforce.com



DESCRIPTION

The highly evolved HTX2 Hybrid Driving Lights include enhancements to the award-winning features that Lightforce pioneered with the HTX, to give our leading driving lights an unfair advantage. Next-generation HTX2 Hybrid Driving Lights evolve every aspect to the next level to give you a high-performance light that's more rugged and reliable than ever.

TECHNICAL SPECIFICATIONS

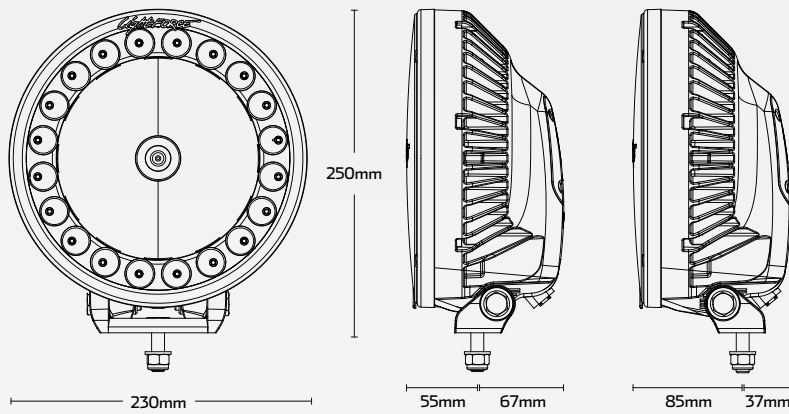

Comprises:

- 1x Lightforce HTX2 hybrid driving light (HTXMK2)
- 1x Lightforce HTX2 clear spot filter (HTXMK2SFL)
- 1x Reversible mounting bracket and hardware
- 1x Matching 4 pin waterproof harness adaptor
- 1x User manual

DRIVING



Beam diagram of a pair of HTX2 lights with spot filters

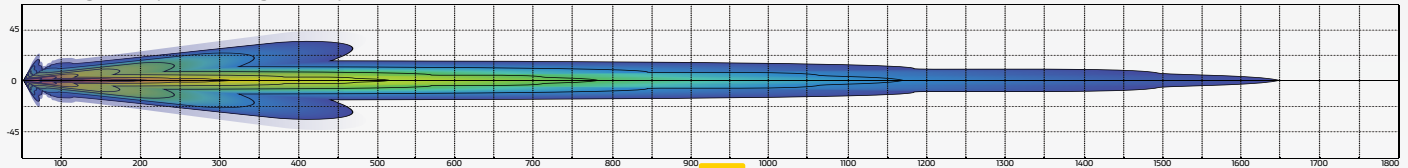

Beam diagram of a pair of HTX2 light with clear combo filters, P/N - HTXMK2CFL (not included)

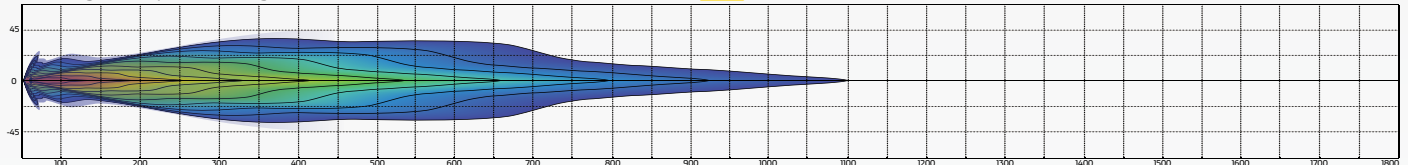

Voltage Range	• 10 Volt - 16 Volt DC	CRI	• 70
Current Draw	• 11.5 Amp @ 12 Volt	Distance @ 1 Lux	• 1,650m (pair)
Wattage	• 130 Watt (LED: 80W / HID: 50W)	Distance @ 0.25 Lux	• 3,300m (pair)
IP Rating	• IP68 & IP69K rated	Effective Lumens	• 8,050 lumens
Colour Temperature	• 5,000K	Raw Lumens	• 11,770 lumens
Operating Temperature	• -40°C to 63°C	Weight (with bracket)	• 2.3kg (5.07lbs)