



12V, 25A Automatic 5 Stage Lithium Battery Charger

#IC2500L

www.projecta.com.au



DESCRIPTION

5 Stage Intelli-Charge battery chargers specifically designed to work with LiFePO4 lithium batteries. Provides the ultimate in safety and performance. Fully automatic with short circuit protection. Can be left connected to the battery without risk of overcharging. The IC2500L easily charges larger sized batteries such as caravan batteries.

FEATURES

- Multi-stage (5 stage) lithium battery charging system
- Features adjustable output and 1.8m temperature compensation probe, for a precise battery charging
- Retains vehicle's computer when charging via power supply mode
- Spark free and polarity protected with durable construction
- Pairable with ICLREMOTE, wired remote control (not supplied) for a more reliable battery charger installation
- 2 year manufacturer warranty

5 Stage Charging Description

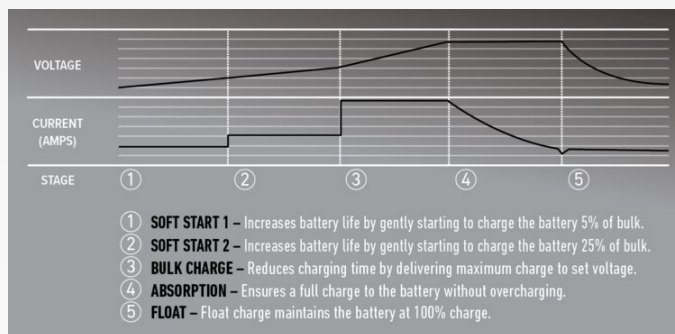

Comprises:

- 1x 5 stage battery charger
- 1x Battery clamps

Dimensions

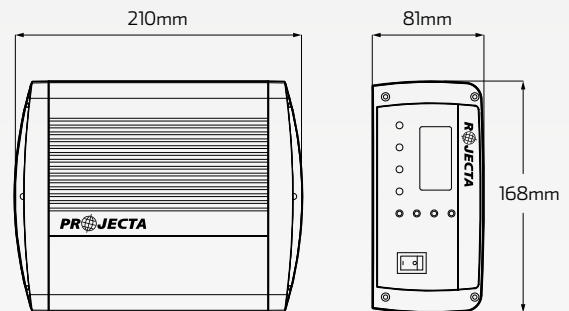

Battery Charge Times

	Volt	Battery Size	Charge Time
Deep Cycle	• 12V	• 4 - 250 Ah	• 2 - 10 Hours

TECHNICAL SPECIFICATIONS

Charger Type	• 5 Stage Automatic
Input Voltage	• 240 Volt AC, 50Hz, 450W
Output Voltage	• 12 Volt
Output Current	• 2, 6, 12, 25 Amp
Minimum Start Voltage	• 1.0 Volt

Back Drain	• Charger 1mA, with remote 2mA
Approvals	• Electrical Safety, EMC
Charge Voltage	• 14.5 Volt
Float	• 13.5 Volt