



9-32V, 50A 5 Stage Dual Battery Charger
#IDC50X

www.projecta.com.au

DESCRIPTION

9-32V, 50A, 5 stage dual battery charger with Multi-Chemistry Technology. Provides an advanced charge simultaneously from both solar & alternator inputs.

Suitable for AGM, Gel, Wet, Calcium & Lithium batteries.



FEATURES

- Direct connections to the IDCX, ensures a reliable perfect connection to the unit
- IP68 & IP69K rated dust and water protection; fully potted with thermal epoxy resin
- Pairable with Intelli-IQ allowing the IDCX to be controlled & monitored portably via Bluetooth
- Over temperature, reverse connection, over/under voltage; total safe guard protection
- Engineered for use with today's modern chemistry types: AGM, Gel, Wet, Calcium & Lithium.

TECHNICAL SPECIFICATIONS

Specifications

Charge Type	• 5 stage
Alternator Input Voltage	• 9-32 Volt
Maximum Solar Input	• 32 Volt DC, 800 Watt
Output Current	• Input: 9-11 Volt DC 37A • Input: 11-32 Volt DC 50A
Supported Batteries	• Gel, AGM, Wet, Calcium & Lithium
Standby Current	• 8mA
Operating Temperature	• -10°C to 80°C
Approvals	• EMC approved
IP rating	• IP68 & IP69K
Warranty	• 5 year manufacturer warranty
Dimensions	• 138mm W x 121mm H x 71mm D

Dimension Diagram

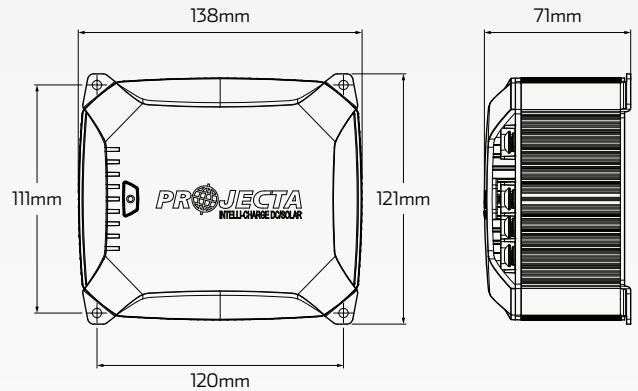

Alternator On/Off

Alternator	12V Vehicle		24V Vehicle	
	Turn On	Turn Off	Turn On	Turn Off
Smart Alternator	12.2 - 20V	<11.9V	24.4 - 32V	<24V
Conventional Alternator	13.4 - 20V	<12.8V	26.8 - 32V	<25.6 V