

ionnic |  Slimline Emergency Lights - Dual 4 LED
#KSLED24B

www.ionnic.com

DESCRIPTION

12-24 Volt, Slimline emergency lights. Features 25 flash patterns with dimming function. Polycarbonate lens and environmentally sealed to IP67. Epoxy encapsulated electronics for environmental & vibration protection. Each individual lights could be synchronised.

Comes with 5 year manufacturer warranty.



TECHNICAL SPECIFICATIONS

Input Voltage	• 12 - 24 Volt
Lens Material	• Polycarbonate lens
Flash Patterns	• 25 flash patterns
Pre-wired Cable	• Yes, 180mm
IP Rating	• IP67 rated
LED Count	• 8 x high powered LED's
Estimate LED Life	• 100,000 hours of operation
Approvals	• SAE J595 Class 1
Dimensions	• 139mm W x 37mm H x 28mm D

Dimensions

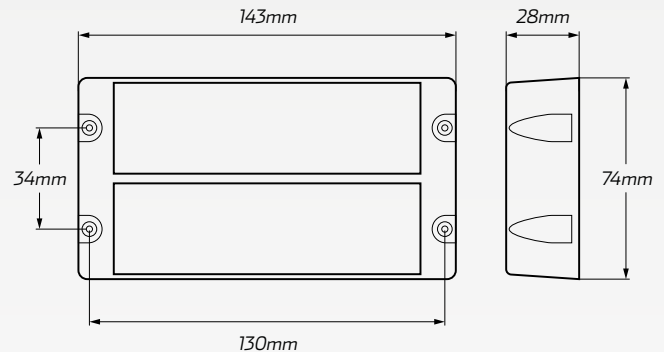

*Clear lens when not illuminated.

TECHNICAL SPECIFICATIONS

Part Number.	LED Colour	Current Draw	Descriptions
KSLED24B-AA	• Amber	• 1.6 Amp @ 12 Volt	• 12 - 24 Volt Dual 4 LED's Slimline emergency lights - Amber LED
KSLED24B-BB	• Blue		• 12 - 24 Volt Dual 4 LED's Slimline emergency lights - Blue LED
KSLED24B-RR	• Red		• 12 - 24 Volt Dual 4 LED's Slimline emergency lights - Red LED
KSLED24B-WW	• White		• 12 - 24 Volt Dual 4 LED's Slimline emergency lights - White LED
KSLED24B-AW	• Amber/White		• 12 - 24 Volt Dual 4 LED's Slimline emergency lights - Amber/White LED
KSLED24B-RB	• Red/Blue		• 12 - 24 Volt Dual 4 LED's Slimline emergency lights - Red/Blue LED