



**12-48V White Noise
Sound Reverse Alarm**
#KT81011

www.ktcables.com.au



DESCRIPTION

12-48V white noise reverse alarm.

Compact design reverse alarm, designed in accordance with SAE J1446 certifications. Produces 87dB of "Shh Shh" sound encapsulated in an IP66 weatherproof resistance housing with universal mounting bracket. Sealed in epoxy to protect against dust, moisture & vibration. Ideal for night work vehicles, mining & industrial applications.

FEATURES

- Multivolt, 12-48 Volt
- Produces a fixed output of 87dB "Shh Shh" noise
- IP66 dust & weatherproof protection
- Universal mounting bracket, 2 bolt terminal installation
- Sealed in epoxy to further protect against dust, moisture & vibration
- Ideal for night work vehicles, mining & industrial applications

TECHNICAL SPECIFICATIONS

Dimension Diagram

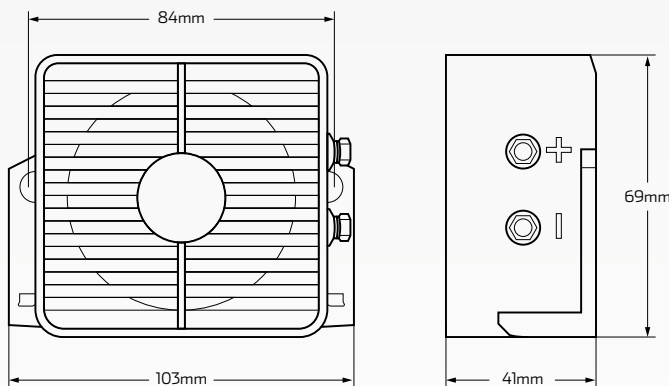

Voltage	• 12-48 Volt
Sound Type	• White noise
Operating Amperage	• 0.1 - 0.5 Amps
Decibels	• 87dB
IP Rating	• IP66 rated
Sounder Unit	• Speaker
Dimensions	• 103mm W x 69mm H x 41mm D
Mounting	• Universal mounting, 2 bolt terminals
Epoxy Sealed	• Yes
Applications	• Night work vehicles • Mining applications • Industrial applications