



10-30V LED Amber Emergency Light Bar

#LB246AM

www.ledautolamps.com



DESCRIPTION

10-30V, LB series LED Amber emergency light bar. Single bolt mount. Equipped with 30 x 1 watt High intensity LED's with up to 30,000 hours of LED Lifespan. Features 18 selectable flash patterns with 360 degrees beam angle, -40°C to 60°C operating temperature.

Comes with 5 year manufacturer warranty.

10V
30V

ECE
COMPLIANT

IP65

5 YEAR WARRANTY

FEATURES

- Multivolt, 10-30V heavy duty amber emergency light bar
- Equipped with 30 x 1W high powered LED's
- Up to 30,000 expected LED lifespan
- Features 18 different selectable flash patterns
- Synchronisable with multiple LB series units
- Dust & waterproof up to IP65 rated
- Meets SAE Class 1 & ECE standard
- Comes with 5 year manufacturer warranty

TECHNICAL SPECIFICATIONS

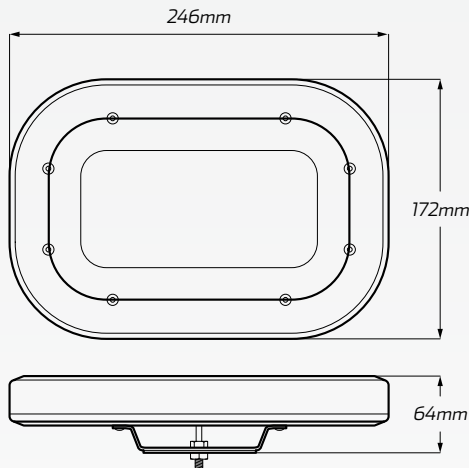

Flash Pattern	FPM	Flash Pattern	FPM
• Rotating (Slow)	• 75	• Quint (All)	• 75
• Rotating (Fast)	• 146	• Steady half	• 123
• Single (Split)	• 75	• Single 2Hz	• 123
• Double (Split)	• 75	• Double 2Hz	• 123
• Triple Flash (Split)	• 122	• Triple 2Hz	• 123
• Quad (Split)	• 75	• Quad 2Hz	• 123
• Single (All)	• 122	• Hyper-Flash (Split)	• 81-500
• Double (All)	• 75	• Mega-Flash (Split)	• 61
• Quad (All) (Class 1)	• 75	• Steady (All)	• N/A

Voltage	• 10 - 30 Volt
Current Draw	• 1.63A @ 13.8V / 0.56A @ 28V
LED Quantity	• 30 x 1 Watt high powered LED's
LED Lifespan	• 30,000 Hours
Beam Angle	• 360° omnidirectional
Flash Patterns	• 18 flash patterns

Operating Temperature	• -40°C to 60°C
IP Rating	• IP65 rated
Base Material	• ABS housing
Lens Material	• Polycarbonate lens
Dimensions	• 246mm L x 172mm W x 64mm H
Pre-wired Cable	• 450mm cable