

**WHITEVISION**  
FUTURE VISION AUTOMOTIVE LIGHTING™

## LED Stop/Tail & Indicator Lamp

www.whitevision.com.au

#LEDCRL105



9V  
33V

ADR  
COMPLIANT

IP67

5 YEAR WARRANTY

### DESCRIPTION

9-33V Heavy duty LED stop/tail & indicator lamp with reflector.

Equipped with rugged PMMA lens & ABS body, this lamp is built to last! Suitable a wide range of automotive applications including trucks, heavy trailers & RV. IP67 rated. ADR approved.

### FEATURES

- Heavy duty stop/tail & indicator lamp
- Equipped with a built-in reflex reflector
- Multi-volt, accepts 9-33V input voltage
- Incredibly rugged, equipped with PMMA lens & ABS base
- Pre-wired with 500mm cable
- ADR approved
- Common dimensions for easy fitting
- Environmentally sealed up to IP67 rating
- Suitable replacement for a wide range of vehicles
- 5 year manufacturer warranty

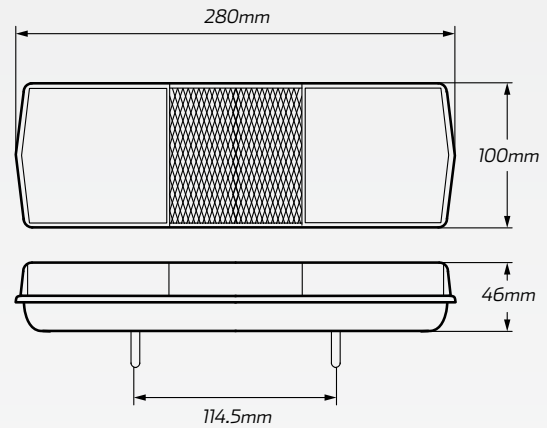

### TECHNICAL SPECIFICATIONS

<b>Function</b>	• Stop/tail & indicator with reflector
<b>Voltage Range</b>	• 9 - 33 Volts
<b>Dimensions</b>	• 280mm W x 100mm H x 46mm D
<b>Input Current</b>	<ul style="list-style-type: none"> <li>• Stop: 1.0 Watt @ 12V</li> <li>• Tail: 0.2 Watt @ 12V</li> <li>• Indicator: 1.0 Watt @ 12V</li> <li>• NPL: 0.6 Watt @ 12V</li> </ul>
<b>Mounting</b>	• Surface mount, sealed studs
<b>Mounting Dimensions</b>	• 114.5 centre to centre

<b>Lens Material</b>	• High impact PMMA lens
<b>Base Material</b>	• ABS base
<b>Cable</b>	• 500mm cable
<b>Approvals</b>	<ul style="list-style-type: none"> <li>• Stop: ADR 49/00 CRN 30655</li> <li>• Tail: ADR 49/00 CRN 30654</li> <li>• Indicator: ADR 6/00 2a CRN 30653</li> <li>• Reflector: ADR 47/00 CRN 30658</li> </ul>
<b>IP Rating</b>	• IP67 rated
<b>Warranty</b>	• 5 year manufacturer warranty