



**LED Stop/Tail,
Ind & Reverse Lamp**
#MAXILAMP3XRW

www.ledautolamps.com



12V
24V

ADR
COMPLIANT

IP67

7 YEAR WARRANTY

DESCRIPTION

12-24 Volt chrome plated bracket LED stop/tail, indicator & reverse lamp. Features a built-in reflector and bolt-on mounting.

Extremely rugged with it's PMMA acrylic lens & ABS base. ADR/ECE approved. Water & dust proof up to IP67 rating.

Comes with a 7 year manufacturer warranty.

FEATURES

- LED stop/tail, indicator & reverse lamp with built-in reflector
- Multivolt, accepts 12 - 24 Volt inputs
- Features a chrome plated bolt-on mounting bracket
- PMMA acrylic lens and ABS base material
- Powered by 90 high powered LED's
- Pre-wired with a 400mm cable
- ADR/ECE approved
- Waterproof up to IP67 rated
- 7 year manufacturer warranty

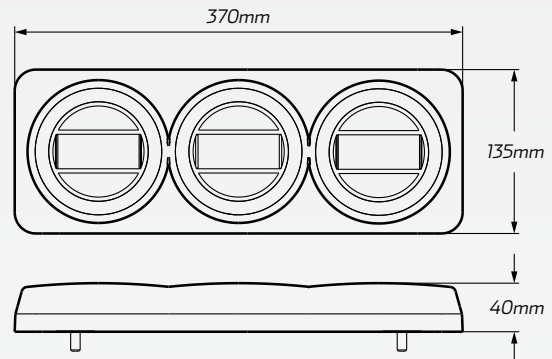

TECHNICAL SPECIFICATIONS

Function	• Stop/tail, indicator & reverse lamp	Lens Material	• PMMA acrylic lens
Voltage Range	• 12 - 24 Volts	Base Material	• ABS base
LED Count	• 90 LED's	Cable	• 400mm cable
Current Draw	<ul style="list-style-type: none"> • Stop: 0.54A @ 13.8V / 0.27A @ 28V • Tail: 0.08A @ 13.8V / 0.04A @ 28V • Indicator: 0.77A @ 13.8V / 0.35A @ 28V • Reverse: 0.67A @ 13.8V / 0.34A @ 28V 	Approvals	<ul style="list-style-type: none"> • Stop/tail: ADR 49/00 CRN 40963 • Indicator: ADR 6/00 2a CRN 40962 • Reverse: ADR 1/00 CRN 40961 • Reflector: ECE 1a-E9-02.1472
Dimensions	• 370mm W x 135mm H x 40mm D	IP Rating	• IP67 rated
Mounting	• 269mm centre to centre	Warranty	• 7 year manufacturer warranty