

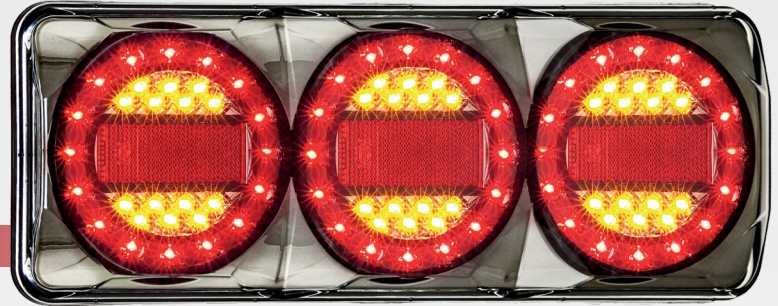

**LED Stop/Tail  
& Indicator Lamp**  
#MAXILAMP3XR

www.ledautolamps.com



12V  
24V

ADR  
COMPLIANT

IP67

7 YEAR WARRANTY

**DESCRIPTION**

12-24 Volt chrome plated bracket LED stop/tail & indicator lamp. Features a built-in reflector and bolt-on mounting.

Extremely rugged with it's PMMA acrylic lens & ABS base. ADR/ECE approved. Water & dust proof up to IP67 rating.

Comes with a 7 year manufacturer warranty.

**FEATURES**

- LED stop/tail & indicator lamp with built-in reflector
- Multivolt, accepts 12 - 24 Volt inputs
- Features a chrome plated bolt-on mounting bracket
- PMMA acrylic lens and ABS base material
- Powered by 90 high powered LED's
- Pre-wired with a 400mm cable
- ADR/ECE approved
- Waterproof up to IP67 rated
- 7 year manufacturer warranty

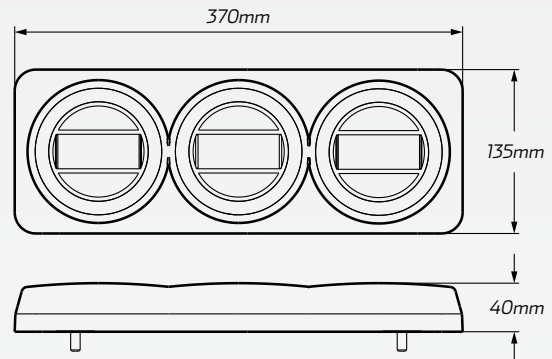

**TECHNICAL SPECIFICATIONS**

<b>Function</b>	• Stop/tail & indicator LED lamp	<b>Lens Material</b>	• PMMA acrylic lens
<b>Voltage Range</b>	• 12 - 24 Volts	<b>Base Material</b>	• ABS base
<b>LED Count</b>	• 90 LED's	<b>Cable</b>	• 400mm cable
<b>Current Draw</b>	• Stop: 0.54A @ 13.8V / 0.27A @ 28V • Tail: 0.08A @ 13.8V / 0.04A @ 28V • Indicator: 0.77A @ 13.8V / 0.35A @ 28V	<b>Approvals</b>	• Stop/tail: ADR 49/00 CRN 40963 • Indicator: ADR 6/00 2a CRN 40962 • Reflector: ECE 1a-E9-02.1472
<b>Dimensions</b>	• 370mm W x 135mm H x 40mm D	<b>IP Rating</b>	• IP67 rated
<b>Mounting</b>	• 269mm centre to centre	<b>Warranty</b>	• 7 year manufacturer warranty