

QVEE

AUTOMOTIVE | MINING | MARINE

www.qvee.com.au

SPST Off/On (Mom)
Waterproof Switch
#MT5508

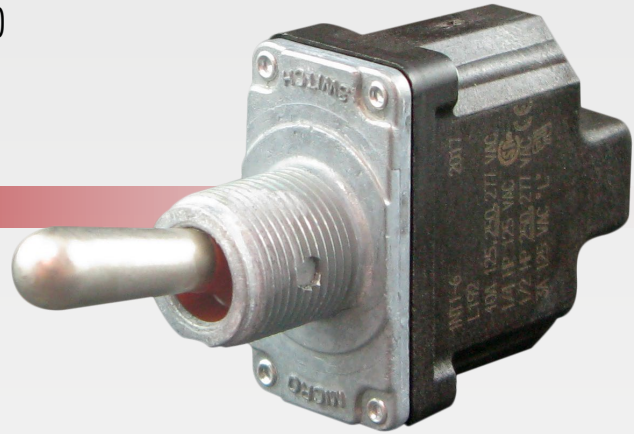

DESCRIPTION

12-24V SPST Off/On (Mom) weatherproof toggle switch with screw on terminals. Suitable for up to 250V AC operation. Dust & waterproof up to IP68 rating. UL recognised, CSA certified.

Amperage: 15A @ 28 Volt.

DIMENSIONS

- Screw on SPST Off/On (Mom) toggle switch
- Multivolt: 12-24 Volt DC, up to 250 Volt AC
- Weatherproof up to IP68 rating
- High impact withstanding thermoplastic case
- UL & CE approved, CSA certified

Panel Cut-out*

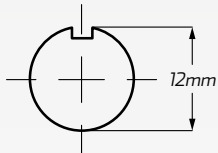

Wiring Diagram

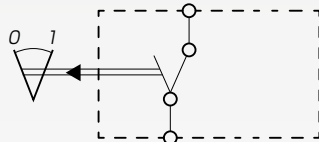

*Measurement allowance: +/- 1mm

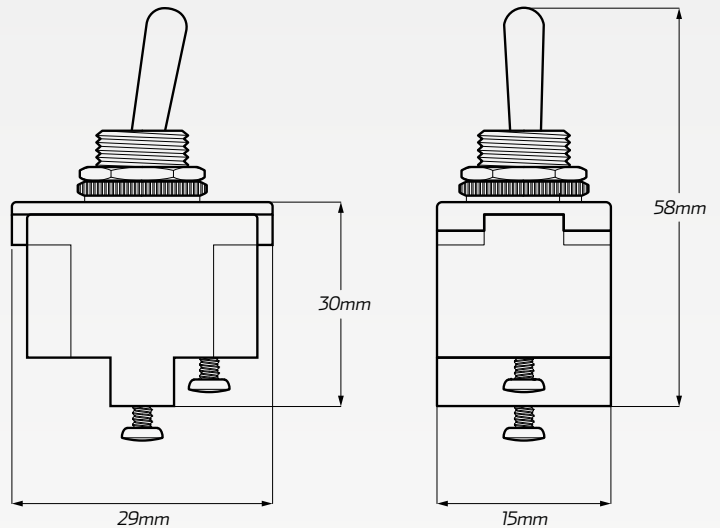

TECHNICAL SPECIFICATIONS

Function	• SPST Off/On(Mom)
Suitable Voltage	• 12-24 Volt DC
Voltage Application	• Up to 250 Volt AC
Current Rating	• 15 Amps @ 28V (resistive load)
Operating Temperature	• -40°C to 70°C
Dimensions	• 58mm H x 29mm W x 15mm D

Mounting Dimensions	• 12mm mounting dia
Body Material	• High impact thermoplastic case
Contact Material	• Silver alloy
IP Rating	• IP68 rated
Approvals	• CE, UL, CSA approvals