

QVEE
AUTOMOTIVE | MINING | MARINE

Heavy Duty Battery
Isolator Switch - SPST
#QVBI2502P

www.qvee.com.au



DESCRIPTION

12-24V, heavy duty, SPST battery isolator switch with red, yellow rubber boots and removeable key. 250A continuous @ 12V, 2000A intermittent @ 12V.

Silver plated copper contacts and M10 zinc plated steel nuts.

FEATURES

- 250 Amp continuous maximum load
- Interchangeable with BOSCH 0341002003 battery isolator switches
- Equipped with red and yellow weatherproof boots to help mark different applications
- Compatible with LockSafe LS11003 and QVEE QVBILO3 battery isolator lockouts

APPLICATIONS

1	• Heavy Truck & Mining Vehicles
2	• Off-Road 4WD
3	• Emergency Vehicles
4	• Marine & Construction Vehicles
5	• Material Handling Vehicles
6	• Agricultural Vehicles

DIMENSIONS

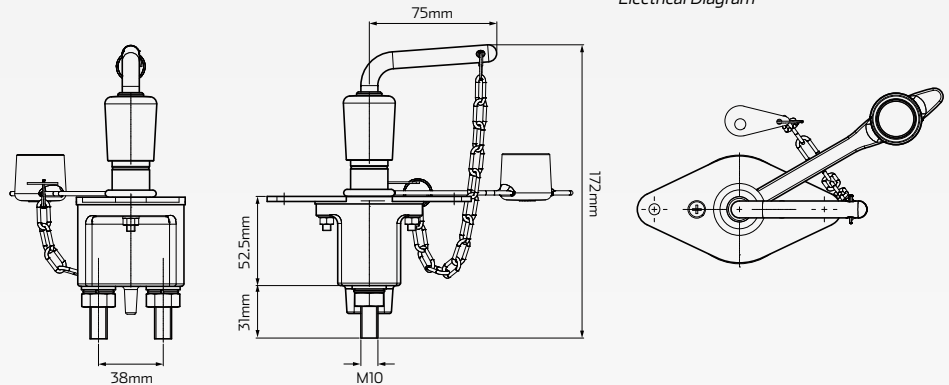

*All measurements are in mm

TECHNICAL SPECIFICATIONS

Voltage	• 12 - 24 Volt	Max Operative Current	• 250 Amp continuous @ 12 V
Highest Load	• 2000A intermittent over 5 sec @ 12V	Terminal Material	• M10 zinc plated steel nuts
IP Rating	• IP65 rated	Contacts Material	• Silver plated copper contacts
Operating Temperature	• -40°C - 85°C	Accessories	• Red and yellow weatherproof boots • Removeable key / achain