

QVEE
AUTOMOTIVE | MINING | MARINE

Heavy Duty Battery Isolator
Switch with Removable Key

#QVBI2504P

www.qvee.com.au

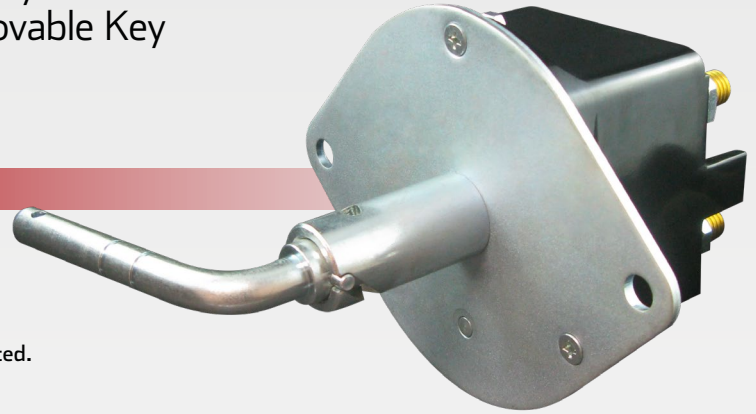

DESCRIPTION

DPST on/off battery isolator switch with removable key.
12-24V, 300A continuous, 1500A intermittent for 10 seconds.
Features bronze plated contacts with metal lever, ignition protected.
IP56 weather protection & M10 silver plated nuts.

FEATURES

- 300 Amp continuous maximum load
- 12 - 24V multi-volt
- 1500A intermittent rating for 10 seconds
- DPST configuration
- Ignition protected
- Weather resistant, IP56 rated
- Bronze plated contacts & M10 zinc plated nuts

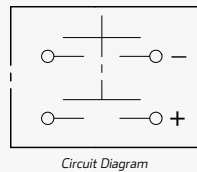
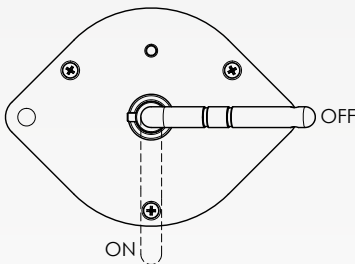
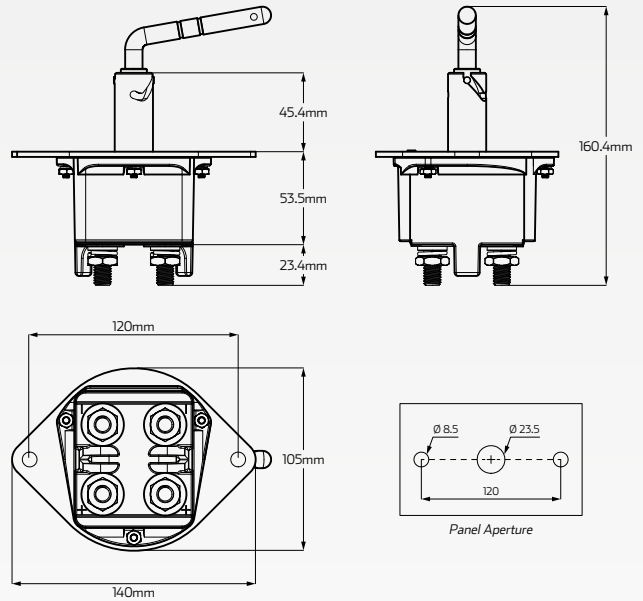

TECHNICAL SPECIFICATIONS

Voltage	• 12 - 24 Volt DC
Continuous Amperage	• 300 Amps
Intermittent Rating	• 1500 Amps for 10 seconds
IP Rating	• IP56 rated

Ignition Protected	• Yes
Contacts Material	• Bronze plated contacts
Dimensions	• 160mm H x 140mm W x 105mm D