

**QVEE**

AUTOMOTIVE | MINING | MARINE

Heavy Duty CCD Colour  
Wireless Reverse Camera

#QVCM87W

www.qvee.com.au

1 YEAR WARRANTY

**DESCRIPTION**

The QVCM86W is an IP69K rated high quality, heavy duty colour CCD wireless reverse camera. Equipped with 4 infrared LED's with up to 15m night vision distance. Suitable for DC 10 - 32 Volt applications.

Perfect for Trucking, Agricultural, Mining, 4WD's, Caravans, RV's & normal passenger vehicles.



**DIMENSIONS**

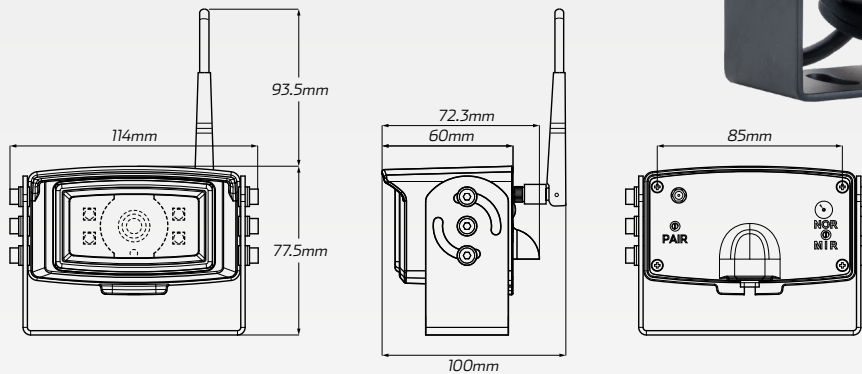

**Comprises:**

- 1 x Colour HD wireless reverse camera
- 1 x Extension antenna
- 1 x Wiring

**TECHNICAL SPECIFICATIONS**

Image Device	• 1/3" CMOS (PC3089)	BLC	• Auto
TV System	• PAL / NTSC	Transmission Distance	• 120m
Effective Pixels	• 756 x 504 pixels	Operation Frequency	• 2400 - 2483.5 MHz
Sensing Area	• 4.80mm x 3.73mm	Receiving Sensitivity	• -89 dBm
Scanning System	• 2:1 Interlace	Video Codec	• MPEG4
Sync. System	• Internal	Frame Rate	• PAL: 25fps / NTSC: 30fps
Horizontal Sync Frequency	• 15.625 kHz (PAL) / 15.734 kHz (NTSC)	Transmission Power	• 18 dBm
Vertical Sync Frequency	• 50 Hz (PAL) / 60 Hz (NTSC)	Spread Spectrum	• FHSS
Minimum Illumination	• 0 Lux (with IR)	Time Delay	• 120ms
Microphone	• Yes	RF Bit Rate	• 4Mbps
Video Output	• 1.0Vp-p, 75 Ohm	Operating Temperature	• -20°C - 70°C, RH 95% Max
Gamma Consumption	• 0.45	Storage Temperature	• -30°C - 80°C, RH 95% Max
AGC	• Auto	Nightvision Distance	• 15m
S/N Ratio	• Better than 46.5dB	Power Supply	• DC 10 - 32 Volt
White Balance	• Auto	IP Rating	• IP69K rated
Electronic Shutter	• 1/60(NTSC) / 1/50(PAL) - 1/10,000 sec	Dimensions (with Antenna)	• 114mm W x 171mm H x 100mm D