

**QVEE**

AUTOMOTIVE | MINING | MARINE

Heavy Duty HD Colour  
Wireless Reverse Camera

#QVCM87WHD

www.qvee.com.au

1 YEAR WARRANTY

**DESCRIPTION**

The QVCM87WHD is an IP69K rated high quality, heavy duty colour HD wireless reverse camera. Equipped with 4 infrared LED's with up to 10m night vision distance. Suitable for DC 10 - 32 Volt applications.

Perfect for Trucking, Agricultural, Mining, 4WD's, Caravans, RV's & normal passenger vehicles.



**DIMENSIONS**

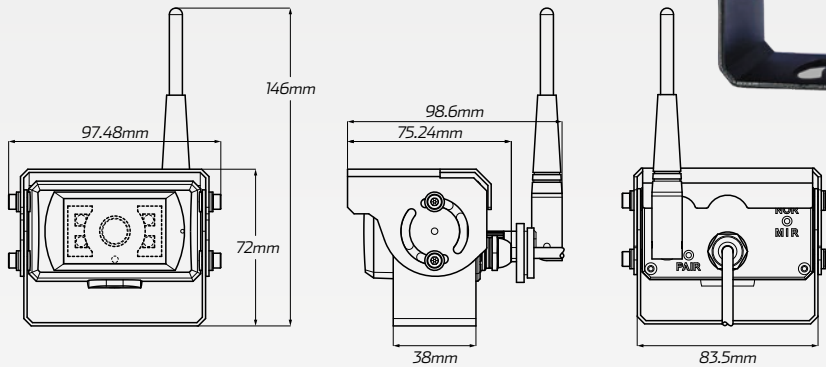

**Comprises:**

- 1 x Colour HD wireless reverse camera
- 1 x Extension antenna
- 1 x Wiring

**TECHNICAL SPECIFICATIONS**

Image Device	• 1/2.9" CMOS	Operation Frequency	• 2403 - 2478 MHz
TV System	• PAL / NTSC	Receiving Sensitivity	• -78 dBm
Effective Pixels	• 1920 (H) x 1080 (V) pixels	Video Codec	• H.264
Scanning System	• Progressive scanning	Modulation	• FHSS
Sync. System	• Internal	Time Delay	• 170ms
Minimum Illumination	• 0.1 Lux (Day), 0 Lux (with IR)	RF Bit Rate	• 12Mbps
Microphone	• Yes	Operating Temperature	• -20°C - 70°C, RH 90% Max
Video Output	• 8 bits YUV	Storage Temperature	• -30°C - 80°C, RH 90% Max
S/N Ratio	• S/N (a-weighted) 38dB	Nightvision Distance	• 8 - 10 metre
White Balance	• Auto	Lens Angle	• 130°
BLC	• Auto	Power Supply	• DC 10 - 32 Volt
Transmission Distance	• FCC: <= 300 metres • CE: <= 200 metres • MIC: <= 60 metres	Power Consumption	• Day: 1.8W-2.5W / Night: 3.6W-4.3W
Transmission Power	• FCC: <= 26dBm • CE: <= 20dBm • MIC: <= 10dBm	IP Rating	• IP69K rated
		Dimensions (with Antenna)	• 97.48mm W x 146mm H x 98.6mm D
		Warranty	• 1 year warranty