

QVEE Female Plug-in
Fusible Link with Lock
#QVLHF

www.qvee.com.au

DESCRIPTION

The QVLHF series is a 32V DC female plug-in fusible link with lock. Features element window. RoHS approved. Suitable for all automotive applications.

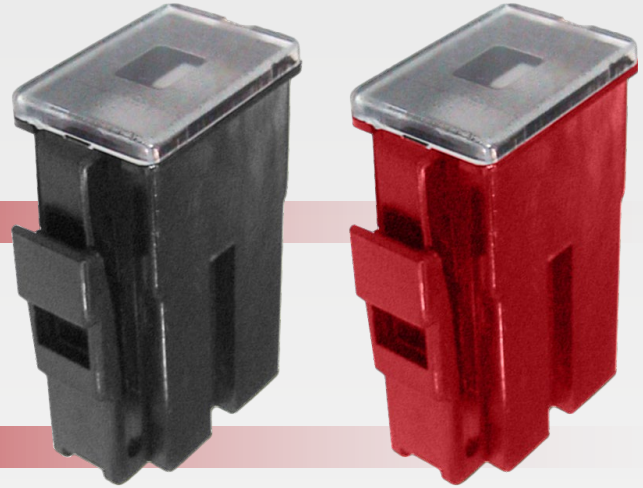

TECHNICAL SPECIFICATIONS

I.R.	• 1000A at 32V DC
Voltage	• 32V DC
Approvals	• ISO 8820 / JASO D612 / RoHS
Dimensions	• 37mm H x 28mm W x 15mm D

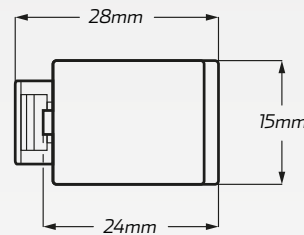

DIMENSIONS

- Height: 37mm
- Width: 28mm
- Depth: 15mm

Time Characteristic % of Amp Rating	Opening Time	
	Min. Time	Max. Time
100%	• 100 Hours	--
200%	• 5 Seconds	• 60 Seconds
350%	• 0.2 Seconds	• 7 Seconds
600%	• 0.04 Seconds	• 1 Seconds

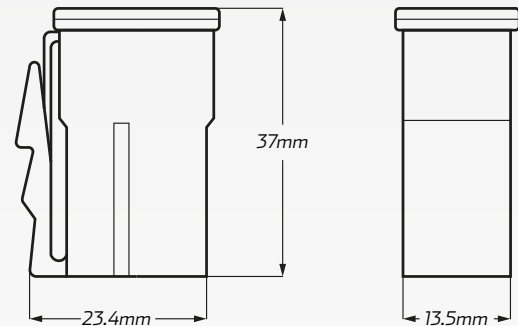

PART NUMBERS

Part Number.	Amperage	Colour	Description
QVLHF045	• 45 Amp	• Red	• 45 Amp red female plug-in fusible link with lock
QVLHF065	• 65 Amp	• Black	• 65 Amp black female plug-in fusible link with lock
QVLHF075	• 75 Amp	• Grey	• 75 Amp grey female plug-in fusible link with lock