

QVEE

AUTOMOTIVE | MINING | MARINE

Switched Dual Tone Reverse Alarm

#QVRABWS

www.qvee.com.au

DESCRIPTION

“Shhh Shhh” & “Beep Beep” dual function reverse alarm.

Easily switch between a standard ‘BEEP BEEP’ audio output at 97dB for daytime use or a white noise / squalker sounding alarm at 97dB for night time use via a switch at the back of the alarm.

Made from high quality nylon & fibre this alarm is water and dust proof with an ingress protection rating of IP66.



FEATURES

- Heavy duty switch adjustable backup alarm
- Day time: “Beep Beep” sound @ 97dB
- Night time: “Shhh Shhh” sound @ 97dB
- SAE & CE approved



2 Year Warranty

TECHNICAL SPECIFICATIONS

DIMENSIONS

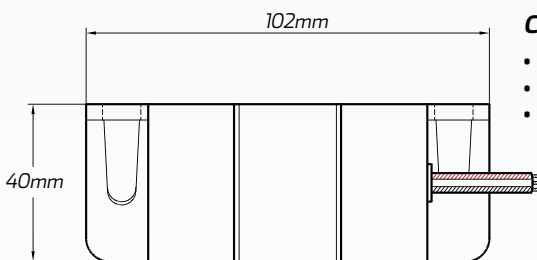
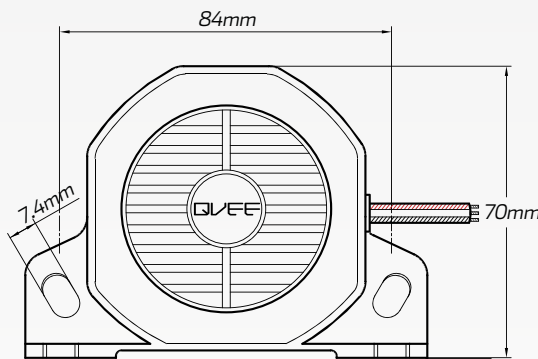

Cable Wiring

- Red: Positive
- White: Control
- Black: Ground

Voltage	• Multivolt 12 - 30 V DC
IP Rating	• IP66
Frequency	• 97dB (Beeper) / 97dB (Squalker)
Operating Temperature	• -40°C to 85°C
Dimensions	• 102mm W x 70mm H x 40mm L
Mounting Hole	• 84mm, Centre to Centre
Function Mode Selection	• Switch
Approvals	• CE Certified • SAE J994

FREQUENCY SPECIFICATIONS

	Traditional 'Beep Beep'	Squalker 'Shhh Shhh'
Decibels	• 97 +/- 4 dB	• 97 +/- 4 dB
Sound Cycles	• 65 per minute	• 73 per minute