

BLASTER ELITE-120 120W Heavy Duty LED Worklight - Spot Beam

www.qvee.com.au

#QVWL120SHDE



ACCESSORIES

- Mine Spec Mounting Brackets & Fittings

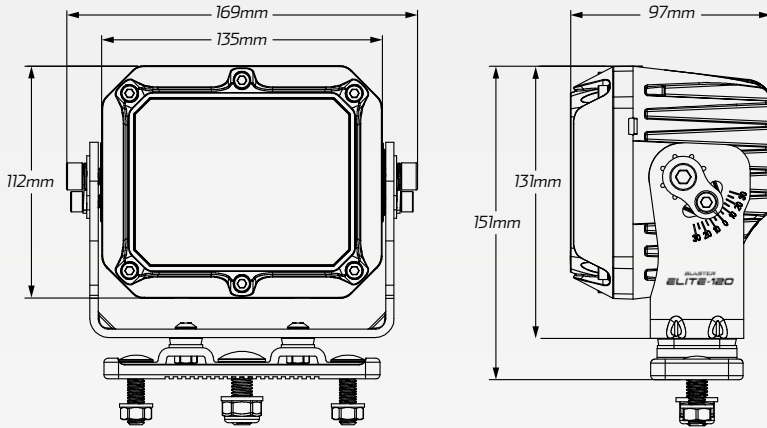

TECHNICAL SPECIFICATIONS

Voltage	• 10 - 32 Volt
Wattage	• 120 Watt
IP Rating	• IP68/IP69K Rated
Raw Lumens	• 10,800 Lumens
Effective Lumens	• 9,000 Lumens
LED Count	• 12 x 10W High Powered Osram® LED's
Beam Coverage	• Flood Beam
Colour Temperature	• 5700 K
Vibration Resistance	• 15G rms 24-2000Hz
Shock Resistance	• 60G
Housing Material	• Die-cast aluminium
Dimensions	• 169mm L x 151mm H x 97mm D
Approvals	• EMC CISPRs 4, CE, RoHS, R10, R112

BEAM COVERAGE

