

BLASTER ELITE-120 120W Heavy Duty LED Worklight - Spot Beam

www.qvee.com.au

#QVWL120SHDE



ACCESSORIES

- Mine Spec Mounting Brackets & Fittings

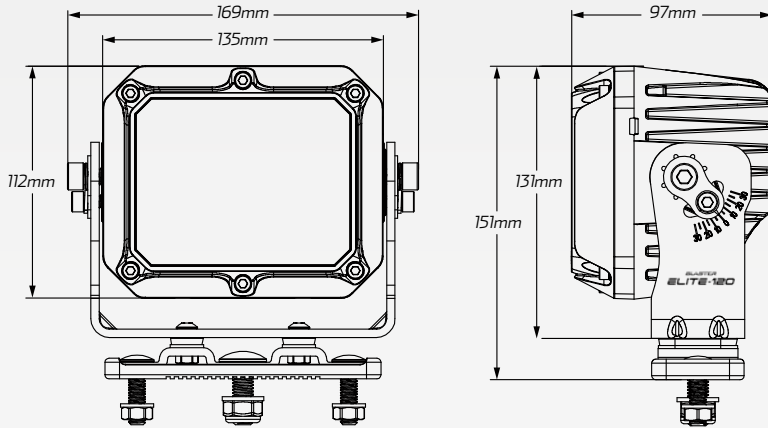

TECHNICAL SPECIFICATIONS

Voltage	• 10 - 32 Volt	Colour Temperature	• 5700 K
Wattage	• 120 Watt	Vibration Resistance	• 15G rms 24-2000Hz
IP Rating	• IP68/IP69K Rated	Shock Resistance	• 60G
Raw Lumens	• 10,800 Lumens	Housing Material	• Die-cast aluminium
Effective Lumens	• 9,000 Lumens	Lens Material	• Polycarbonate Lens
LED Count	• 12 x 10W High Powered Osram® LED's	Dimensions	• 169mm L x 151mm H x 97mm D
Beam Coverage	• Spot Beam	Approvals	• EMC CISPRS 4, CE, RoHS, R10, R112

