

QVEE 60W Heavy Duty LED Worklight - Flood Beam
BLASTER SERIES #QVWL60MFHD

www.qvee.com.au

DESCRIPTION

The QVEE 60W "Blaster" worklight gives a reliable illumination. Equipped with 6 x 10W high performance Osram® LED's, producing up to 6,000 Lumens, your work area will always be well illuminated.

Featuring IP69K rated housing & Ultra Heavy Duty mounting bracket. You can be confident that this light will take the punishment from the harsh mining, industrial & agricultural environments.

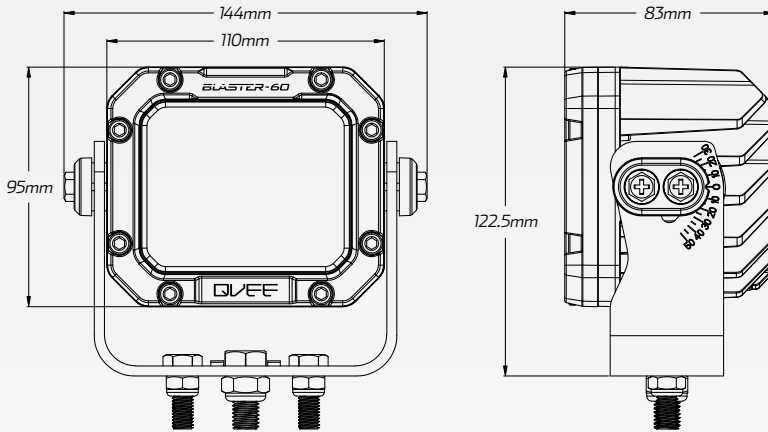

ACCESSORIES

- Heavy Duty Mounting Brackets & Fittings

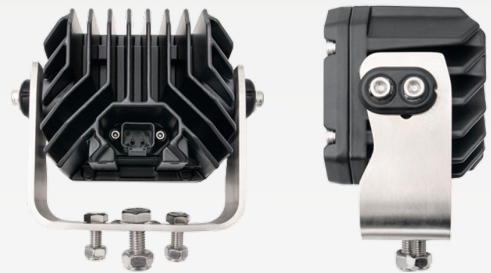

TECHNICAL SPECIFICATIONS

Voltage	• 9 - 32 Volt
Wattage	• 60 Watt
IP Rating	• IP69K Rated
Raw Lumens	• 6,000 Lumens
Efficient Lumens	• 5,100 Lumens
LED Count	• 6 x 10W High Powered Osram® LED's
Beam Coverage	• Flood Beam
Colour Temperature	• 5700 K
Vibration Resistance	• Up to 30G
Housing Material	• ADC 12 Aluminium Housing
Lens Material	• Polycarbonate Lens
Dimensions	• 144mm L x 122.5mm H x 83mm D
Approvals	• EMC/EMI Rating: CISPR 25 - Class 4

BEAM COVERAGE

