



97dB Beeper
SRC Reverse Alarm
#RA520

www.eccosafetygroup.com.au



DESCRIPTION

12-24V Compact reverse alarm. Produces 97dB of traditional "Beep Beep" signal while active. The SRC (Self Resonating Circuitry) allows the alarm to monitor it's frequency and adjust to optimal level at different conditions, always maintaining an effective warning signal.

Glass filled nylon housing, self grounding & stud terminal connection. -40°C to 85°C operating temperature. SAE approved.

FEATURES

- Compact design & universal mounting; flexible instalation options
- Equipped with SRC (Self-Resonating Circuitry), monitors the alarm and adjusti it to optimal FQ in different conditions
- Produces a "Beep Beep" noise
- Decibel rating: 97dB
- Multi-volt: 12 - 24 Volt DC
- -40°C to 85°C operating temperature
- SAE J994 Type C, AMCA, UL, CE , E approved
- 2 year manufacturer warranty

TECHNICAL SPECIFICATIONS

DIMENSIONS

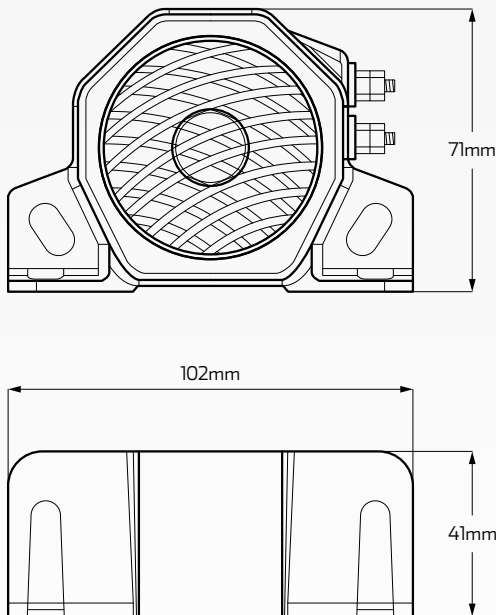

Voltage	• 12 - 24 Volt DC
Amperage	• 0.2 Amps
Frequency	• 97dB
Operating Temperature	• -40°C to 85°C
Sound Type	• Beep Beep
Dimensions	• 102mm x 71mm x 41mm
Mounting Hole	• 83mm CTC
Mounting Studs	• #8-32 studs
Approvals	• SAE J994 TypeC, AMCA, UL, CE , E
Warranty	• 2 year manufacturer warranty