



92dB "Broadband"
Sound Reverse Alarm

#RABBS92

www.brigade-electronics.com



DESCRIPTION

"Shhhh Shhhh" Broadband sound reverse alarm. The BBS-TEK broadband alarms use multi-frequency broadband sound instead of the traditional single frequency sound of a conventional alarm. The sound dissipates much quicker, is directional, and localised in the danger zone, resulting in an enormous reduction in noise and nuisance complaints.

FEATURES

- Multi-frequency broadband sound
- Instantly locatable
- Sound confined to danger area
- Eliminates noise nuisance
- Sounder unit: speaker
- Water and dust proof - IP68



TECHNICAL SPECIFICATIONS

DIMENSIONS

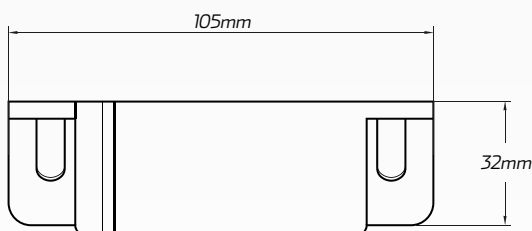
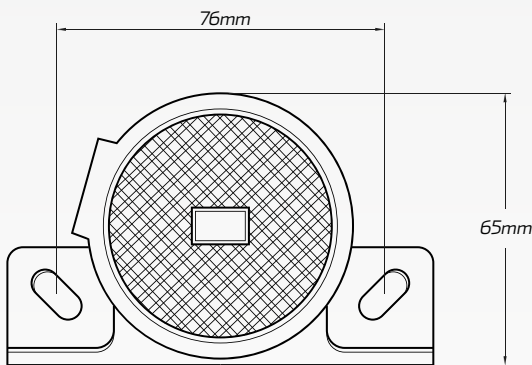

| | |
|------------------------------|--|
| Voltage | • Multivolt 12 - 24 V DC |
| IP Rating | • IP68 |
| Amperage | • Max 0.5 Amps |
| Decibels @ 1m | • 92dB |
| Frequency | • Multi |
| Sounder Unit | • Speaker |
| Mechanical Vibration | • 10 G |
| Operating Temperature | • -40°C to 85°C |
| Dimensions | • 105mm W x 65mm H x 37mm L |
| Hole Centres | • 76mm / 3" |
| Approvals | <ul style="list-style-type: none"> • CE Marker • EMC Approved: E • SAE J994 |