

THE POWER OF  
**REDARC**®

## Tow-Pro Elite V3 Electric Brake Controller

#REBRH-ACCV3

www.redarc.com.au

### DESCRIPTION

Tow-Pro Elite V3 is the 3rd generation in the REDARC's electric brake controller series. With new software upgrades and features, this next generation of Tow-Pro Elite continues to set its name as the benchmark trailer brake controller in Australia.



### FEATURES

- Software upgrades resulting in a smoother braking response for heavy trailer and caravans.
- Suitable for use with all modern vehicles
- New-look control knob (meets ADR21 standard), allowing a quicker and easier installation of the Tow-Pro elite
- Simple to install and operate and can be automatic or user controlled
- Suitable for both electric and hydraulic trailer brakes
- Suitable for 12 / 24 Volt systems
- AL-KO ESC & Dexter Sway Control System approved

#### Kit Content:

- 1 x Remote head assembly
- 1 x Main unit
- 1 x Remote head nut
- 1 x Remote head knob
- 1 x Remote head bezel
- 1m x Remote head cable
- 0.5m x Main unit wires & connectors

### TECHNICAL SPECIFICATIONS

Operating Voltage	• 9 Volt - 32 Volt
Nominal Input Voltage	• 12 / 24 Volt
Standby Current	• < 5mA
Operating Temperature	• -20°C to 60°C
Weight	• 200 g

Input Voltage	12 Volt	24 Volt
Brake Input Signal Voltage	OFF: 0V, ON: +12V nominal	OFF: 0V, ON: +24V nominal
Brake Coil Voltage	12V	24V
Max. Trailer Axles	3 Axles	3 Axles
Nominal Current Draw	18A	18A
Max. Rated Current	25A	30A

### DIMENSIONS

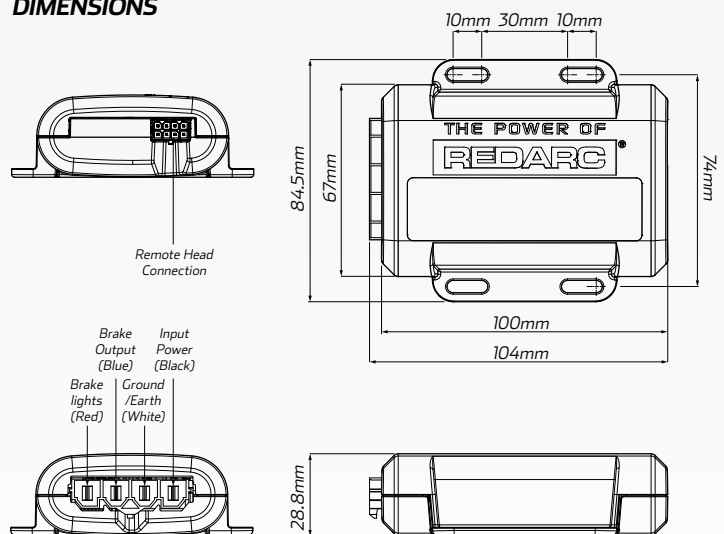

The Tow-Pro Elite can be mounted in any orientation as long as the installation is secure and the main unit cannot move or change orientation once installed. A change in orientation will affect system calibration.