

QVEE
AUTOMOTIVE | MINING | MARINE

Mine Bar with
Dual Slimline Beacon
#RHBAR1250-NT22L

www.qvee.com.au

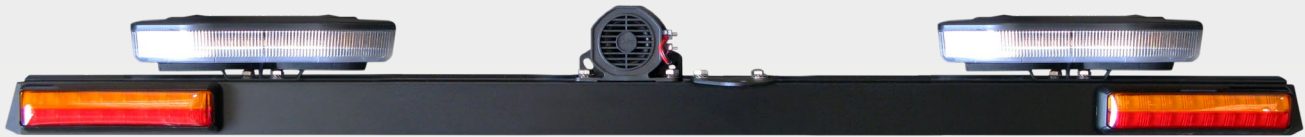

PRODUCT BREAKDOWN

Part No.	Description	Qty
QVRB1	• Black alloy mine bar	• 1
QVCNKIT	• Channel nut kit	• 2
QVRB250	• "QVEE" Heavy duty LED slimline beacon	• 2
201BSTIB	• "LED Autolamps" stop/tail/indicators	• 2
QVRABWS	• "QVEE" 97dB dual tone reverse alarm	• 1
QVBRK5	• Black, powder coated flag/worklight bracket	• 1
37C	• 3mm, 7 core trailer cable (7m)	• 7

DIMENSIONS

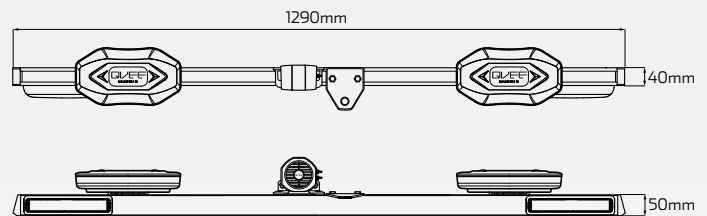

- Accessories come pre-assembled
- Beacon is mounted with a stainless steel bracket
- Comes pre-wired with QVDT2HALF, 2 pin male Deutsch connector

TECHNICAL SPECIFICATIONS

GENERAL SPECIFICATIONS

Bar Dimensions	• 50mm x 40mm x 1290mm
Cable Wiring	• 3mm 7 core trailer cable (7m)

BEACON - QVRB250

LED Count	• 40 SMD LED's
Input Voltage	• 10 - 30 Volt DC, 40 Watt
Colour	• Amber, 20 different flash patterns
IP Rating	• IP67 Rated

REVERSE ALARM - QVRABWS

Sound Type	• "Beep Beep" & "Shhh Shhh" (change via switch)
IP Rating	• IP66 Rated
Decibel Level	• 97dB

FLAG / WORKLIGHT BRACKET - QVBRK5

Mounting Hole	• 14mm Diameter
Coating	• Black Powder Coating

STOP / TAIL / INDICATOR - 201BSTIB

Input Voltage	• 12 Volt only
IP Rating	• IP67 Rated
Approvals	• Stop - ADR Category 49/00 CRN 46885 • Tail - ADR Category 49/00 CRN 46885 • Indicator - ADR Category 49/00 CRN 46884

TRAILER CABLE - 37C

Conductor	• Plain copper conductor to AS1125
Insulation	• UV stabilised V90-HT PVC to AS 3202:2000
Voltage	• AC 50V / DC 120V to AS/NZS 3000:2000

MINE BAR WITH DUAL SLIMLINE BEACON

RHBAR1250-NT22L Dimension Diagram

Dimensions:

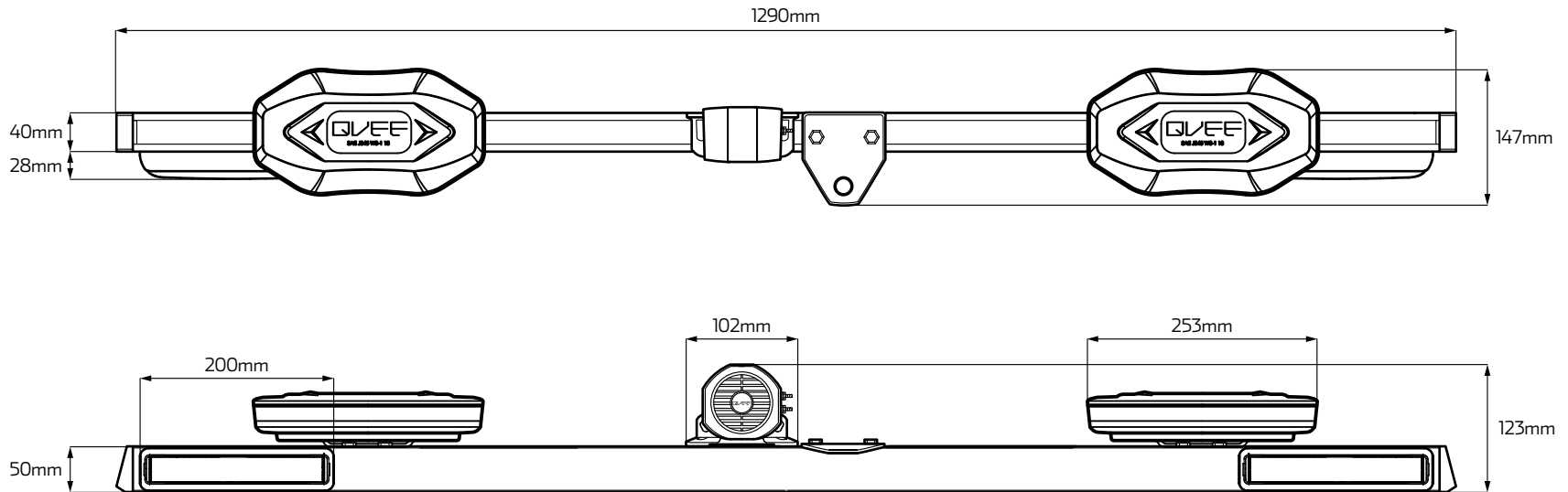

+Allowance of +/- 3mm.

*To avoid warranty issues QVEE recommends product are fitted by a qualified Auto Electrician.

1250MM / 1375MM / 1500MM MINE BAR Wiring Diagram

Wiring Diagram*:

