

**QVEE**  
AUTOMOTIVE | MINING | MARINE

Mine Bar with ECCO® Rotating Amber Beacon

#RHBAR1250-NT25

www.qvee.com.au



**PRODUCT BREAKDOWN**

| Part No. | Description                                   | Qty |
|----------|---|-----|
| QVRB1    | • Black alloy mine bar                        | • 1 |
| QVCNKIT  | • Channel nut kit, 8mm hole                   | • 5 |
| 7660A    | • "ECCO" Class 1 LED rotating amber beacon    | • 1 |
| H2378    | • "Hella" stop/tail/indicator light           | • 2 |
| QVRABWS  | • "QVEE" 97dB dual function reverse alarm     | • 1 |
| QVBRK5   | • Black, powder coated flag/worklight bracket | • 1 |
| 37C      | • 3mm 7 core trailer cable                    | • 7 |

**DIMENSIONS**

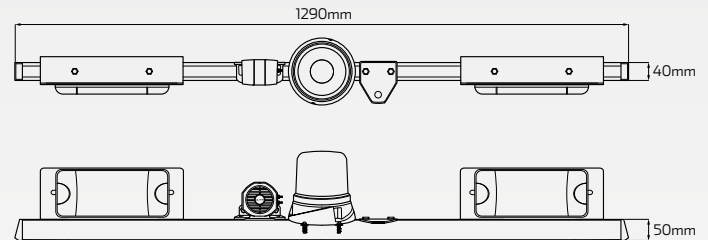

- Accessories come pre-assembled
- Beacon and indicators are mounted with BRK1 & BRK3 stainless steel bracket
- Comes pre-wired with 2 pin Deutsch connector & 3mm 7 core trailer cable

**TECHNICAL SPECIFICATIONS**

**GENERAL SPECIFICATIONS**

|                |                                 |
|----------------|---------------------------------|
| Bar Dimensions | • 1290mm L x 50mm H x 40mm D    |
| Cable Wiring   | • 3mm 7 core trailer cable (7m) |

**FLAG / WORKLIGHT BRACKET - QVBRK5**

|               |                        |
|---------------|------------------------|
| Mounting Hole | • 14mm Diameter        |
| Coating       | • Black Powder Coating |

**BEACON - 7660A**

|               |                             |
|---------------|-----------------------------|
| Input Voltage | • 12 - 24 Volt DC           |
| Colour        | • Amber, 125 RPM rotator    |
| IP Rating     | • IP67 Rated                |
| Approvals     | • SAE J845 Class 1, ECE R10 |

**STOP / TAIL / INDICATOR - H2378**

|               |   |
|---------------|---|
| Input Voltage | • Multivolt - 12/24 Volt  |
| IP Rating     | • IP6K7 & IP6K9K Rated  |
| Approvals     | • E24 5883<br>• ADR 6/00: Cat 2a, ADR 49/00<br>• ECE R6/01, ECE R7/02 |

**REVERSE ALARM - QVRABWS**

|               |   |
|---------------|---|
| Sound Type    | • "Beep Beep" & "Shhh Shhh" (change via switch) |
| IP Rating     | • IP66 Rated                                    |
| Decibel Level | • 97dB  |

**TRAILER CABLE - 37C**

|            |  |
|------------|--|
| Conductor  | • Plain copper conductor to AS1125         |
| Insulation | • UV stabilised V90-HT PVC to AS 3202:2000 |
| Voltage    | • AC 50V / DC 120V to AS/NZS 3000:2000     |

# MINE BAR WITH ECCO® ROTATING BEACON

## RHBAR1250-NT25 Dimension Diagram

Dimensions:

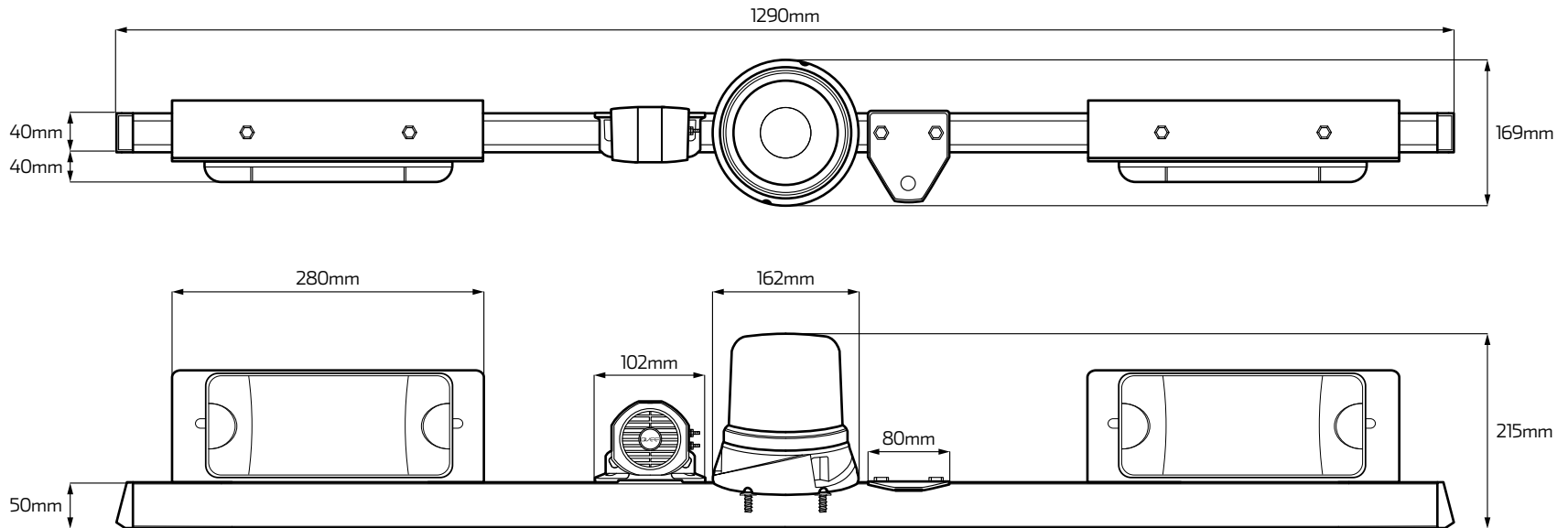

+Allowance of +/- 3mm.

\*To avoid warranty issues QVEE recommends product are fitted by a qualified Auto Electrician.

# 1250MM / 1375MM / 1500MM MINE BAR Wiring Diagram

## Wiring Diagram\*:

