

QVEE
AUTOMOTIVE | MINING | MARINE

Mine Bar with Slimline Beacon & Worklight

#RHBAR1250-NT3

www.qvee.com.au



PRODUCT BREAKDOWN

Part No.	Description	Qty
QVRB1	• Black alloy mine bar	• 1
QVCNKIT	• Channel nut kit, 8mm hole	• 4
QVRB250	• "QVEE" Heavy duty LED slimline beacon	• 1
QV9L28WF	• "QVEE" 27W flood worklights	• 2
20IBSTIB	• "LED Autolamps" stop/tail/indicators	• 2
QVRABWS	• "QVEE" 97dB dual function reverse alarm	• 1
QVBRK5	• Black, powder coated flag/worklight bracket	• 3

DIMENSIONS

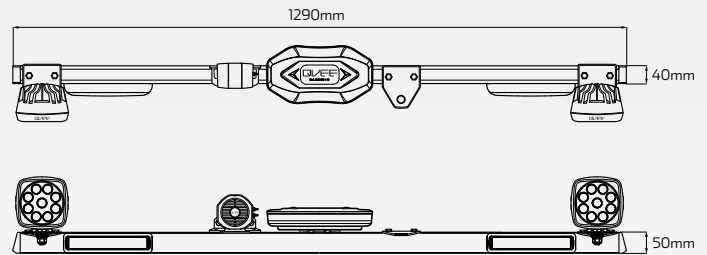

- Accessories come pre-assembled
- Beacon is mounted with a stainless steel bracket
- Comes pre-wired with 2 pin male Deutsch connector & 7 core trailer cable

TECHNICAL SPECIFICATIONS

GENERAL SPECIFICATIONS

Bar Dimensions	• 1290mm L x 50mm H x 40mm D
Cable Wiring	• 3mm 7 core trailer cable (7m)

FLAG / WORKLIGHT BRACKET - QVBRK5

Mounting Hole	• 14mm Diameter
Coating	• Black Powder Coating

BEACON - QVRB250

LED Count	• 40 SMD LED's
Input Voltage	• 10 - 30 Volt DC, 40 Watt
Colour	• Amber, 20 different flash patterns
IP Rating	• IP67 Rated

STOP / TAIL / INDICATOR - 20IBSTIB

Input Voltage	• 12 Volt only
IP Rating	• IP67 Rated
Approvals	<ul style="list-style-type: none"> • Stop - ADR Category 49/00 CRN 46885 • Tail - ADR Category 49/00 CRN 46885 • Indicator - ADR Category 49/00 CRN 46884

REVERSE ALARM - QVRABWS

Sound Type	• "Beep Beep" & "Shhh Shhh" (change via switch)
IP Rating	• IP66 Rated
Decibel Level	• 97dB

WORKLIGHT - QV9L28WF

Beam Type	• Flood beam
Lumens	• 9 High powered CREE® LED's - 2,700 Lumens
IP Rating	• IP68 Rated

MINE BAR WITH SLIMLINE BEACON & WORKLIGHTS

RHBAR1250-NT3 Dimension Diagram

Dimensions:

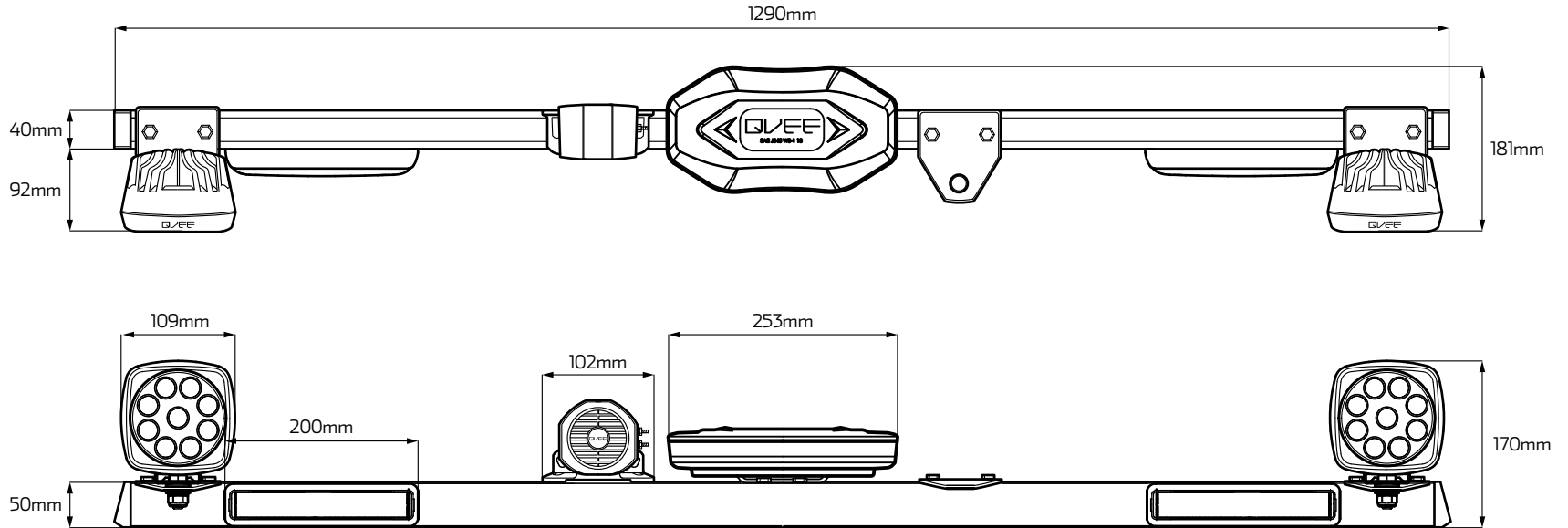

+Allowance of +/- 3mm.

*To avoid warranty issues QVEE recommends product are fitted by a qualified Auto Electrician.

1250MM / 1375MM / 1500MM MINE BAR Wiring Diagram

Wiring Diagram*:

